

KEEYA

COMPLETE SET EQUIPMENT PRODUCT SELECTION GUIDE



KEEYA

www.cnkeeya.com



Scan the official website

KEEYA Electric

ADD : 208 Wei 12 Road, Leqing Economic Development Zone, Zhejiang Province, China
TEL : 0577-61568666 FAX : 0577-61568662 HTTP : www.cnkeeya.com

KEEYA
ENERGY
EFFICIENCY

- This manual is printed by Keeya Power Equipment Co., Ltd. only for the description of some product-related qualification information
- Improve the contents of this manual at any time due to technical upgrades or new production processes without prior notice
- Please contact us at any time when ordering. Please confirm the relevant information
- Reproduction in whole or in part without permission
- Continuous product development and continuous innovation

© Keeya Power Equipment Co., Ltd. all rights reserved

Cherish resources and be kind to the environment

鼎诺传媒 企案策划手册
DINGNUO MEDIA 158 6349 9988

Zhejiang Hanya Electric Appliance Co., Ltd

KEYWAY

**Grateful for you
Walk all the way**



KEEYA — Company Profile

Focus on transmission and distribution and control equipment manufacturing

Hanya Electric Appliance Co., Ltd, founded in 2009, is a comprehensive modern science and technology enterprise integrating power equipment resource development, manufacturing, domestic electrical equipment sales and import and export power equipment agency. Providing perfect power supply system for customers is KEEYA's mission!

The company is committed to building a high-tech enterprise integrating industry and trade. The group mainly develops and produces: high and low voltage complete sets of equipment, box type substation, power transformer, box type switching station, cable branch box, stainless steel distribution box and other transmission and distribution products, which can meet the needs of customers in all walks of life. Keeya has a registered capital of 100 million yuan and has passed three certifications of quality management, environmental management and occupational health and safety management system. We can provide reasonable and perfect equipment pre-sale, sale and after-sales service with exquisite technology for a long time.

KEEYA attaches great importance to scientific development and the construction of high-quality talent team. At the same time, the company has strictly implemented various development plans in recent years, laying the foundation for the company's subsequent leapfrog development! All kinds of products produced by the company have achieved very good test results in the quality supervision, inspection and testing in Sichuan, Chongqing, Shaanxi, Yunnan, Tianjin, Hebei and other places, and have been fully affirmed and trusted by the majority of customers in the power industry.



Solicitude and
Gratitude

Keeya Power

Equipment Development and Hand in hand

KEEYA has gone through an extraordinary course of ten years, recalling the hard road of entrepreneurship, striving for hard work, continuous innovation, adhere to development.

Ten years later, we will not stop. Company staff continue to work together, hard work, down-to-earth work, under the concern and support of social from all walks of life, for the society to provide economic, safe and reliable grid, in order to realize "the domestic first-class equipment suppliers for transmission and distribution field, leading the domestic equipment manufacturing progress" of the vision, striving to develop, advance hand in hand.

携手

KEEYA — Precision equipment
Strict manufacturing technology, high quality products

Scientific production technology, strict quality system and strict raw material procurement system ensure the quality of KEEYA electric products. In KEEYA electric appliances, we not only guarantee to provide you with excellent cost performance, complete and high quality products, but also bring you energy saving and environmental protection environment, because the products of KEEYA electric appliances fully meet the national quality, energy saving, safety and environmental protection standards, some of the quality of products is even better than the quality of similar products in Europe.

Robot welding system

Box body adopts robot welding, which is more reliable and more beautiful than traditional manual welding. This equipment adopts Panasonic robot, visual vision system is applied to the welding of inflatable cabinet products, which can greatly improve the welding quality and welding speed.

Accurate minute
Adhering to the
Craftsmanship



KEEYA — Workshop and Testing
R&d and technology company development is a top priority

High-quality research team

KEEYA have a by a number of senior titles of technical engineers composed of high-quality scientific research team, in the introduction, digestion, absorption on the basis of domestic technology, formed the unique innovation mechanism, in the transformation of basic research, product development, market formed the perfect technological innovation system, build a huge intangible assets of enterprises and the core competitive ability.

Professional testing, quality assurance

The company puts product quality in an important position and strictly implements ISO9001 quality system in the actual production process. The quality department of the company is equipped with a number of precision testing instruments, and makes strict quality standards. With precise and rigorous quality control attitude, achieve from raw materials to finished products in all aspects of quality control. Each operation process is strictly controlled to establish the quality benchmark of "KEEYA".

Helium leak detector

Dry leak detection was carried out on the switch cabinet cabinet by helium leak detector, and the workpiece and the true empty box were vacuumed synchronously to make the pressure difference between the workpiece and the true empty box not greater than 0.04mpa. Helium was filled into the detected workpiece, and helium mass spectrometry was used to detect the gas tightness, so as to ensure that the annual gas leakage rate of the product was less than 0.1%.



Innovative R&D
Build keeya core strength



QY-SRM16 Fully insulated inflatable ring switch equipment ----- 01



(YQ)XGN15 AC metal enclosed ring network switchgear ----- 03



QY-GTXGN-12 Solid fully insulated closed ring network switchgear ----- 05



QYAir-12/T630-25 Environmentally friendly gas-insulated metal-enclosed switchgear ----- 07



DFW-12/24 Series telescopic branch box ----- 09



DFW Series telescopic branch box ----- 11



YB□-12 Prefabricated substations ----- 13



ZGS13-12/0.4 Combined American prefabricated substation ----- 15



10-35kV Modular prefabricated cabin substation ----- 17



KYN61-40.5 Armored removable AC metal-enclosed switchgear ----- 19



KYN28-12 Armored removable AC metal-enclosed switchgear ----- 21



MNS Low-voltage withdrawable switchgear ----- 23



GCS Low-voltage withdrawable switchgear ----- 25



GCK Low-voltage withdrawable switchgear ----- 27



GGD AC Low Voltage Switchgear ----- 29



GGJ Capacitor bank ----- 31



XL-21 Power cabinet ----- 33



QYV-12D/630-25 SF6 gas-filled cabinet circuit breaker (with isolation belt grounding) ----- 35



QYV-12D/630-25 SF6 gas-filled cabinet circuit breaker (without isolation and without grounding) ----- 37



QYV-12D/630-31.5 SF6 inflatable cabinet load switch ----- 39



Solid Cabinet Movement ----- 41



FLN36-12D AC High Voltage Sulfur Hexafluoride Load Switch ----- 43



QYV(VS1)-12 Fixed indoor high voltage vacuum circuit breaker ----- 45



ZW32-12F Outdoor AC high voltage demarcation vacuum circuit breaker ----- 47



ZW20-12F Intelligent vacuum circuit breaker (watchdog) ----- 48



S11-M Fully sealed oil-immersed power transformer ----- 49



SC(B)10 Epoxy resin cast dry type transformer ----- 51



S13-MRL Triangular three-dimensional wound iron core power transformer ----- 53



Single-phase oil-immersed transformer ----- 55

QY-SRM16

Fully insulated inflatable ring switch equipment



Overview

The QY-SRM16 fully insulated inflatable ring network switchgear produced by the company has passed the type test of the National High Voltage Electrical Test Center. The product is widely used in 10kV/6kV power distribution system, and is the switch product of choice for various urban and rural users' transformation and distribution systems.

The switchgear is a modular unit model, which can be combined according to different purposes; it is divided into two categories: fixed unit combination and expandable unit, to meet the needs of various substations for flexible use of compact switchgear.

QY-SRM16 fully insulated gas-filled ring network switchgear is a completely sealed system, and its live parts and switches are enclosed in a stainless steel body. The entire switchgear is not affected by external environmental conditions, thus ensuring operational reliability and personal safety. And it is maintenance-free. By choosing an expandable bus, any combination can be achieved to achieve full modularity. Extended busbar safety insulation and shielding ensures reliability and safety. QY-SRM16 fully insulated gas-filled ring network switchgear can also provide TV-based automation solutions, form the concept of intelligent switch, and minimize the workload of on-site installation and debugging.

QY-SRM16 fully insulated gas-filled ring network switchgear is divided into non-extended standard configuration and scalable standard configuration. Due to the combination of full and half modules and self-expandability, it has a very special flexibility.

QY-SRM16 fully insulated gas-filled ring network switchgear implements GB standard. The design life for operation under indoor conditions (20°C) exceeds 30 years.

Model meaning

QY SRM6 - 12 - □ / □ □ □

① ② ③ ④ ⑤ ⑥ ⑦

①	Enterprise code
②	Type
③	Rated voltage: 12 rated voltage 12kV; 24 rated voltage 24kV
④	Cabinet name: C : load switch cabinet; F : fuse combination cabinet; V : vacuum circuit breaker cabinet; SV, SL: busbar segment cabinet; M : measuring cabinet; PT : PT cabinet (common cabinet is composed of C, F, V, SV, SL arbitrarily.)
⑤	Rated current: 630 rated current 630A; 1250 rated current 1250A
⑥	Extension type: I: left extension; D: right extension; ID: both sides extension; blank: not extension
⑦	Cable entry and exit method: L: left cable entry and exit; R: right cable entry and exit; LR: both sides cable entry and exit Blank: front entry and exit

For example:

1. QY-SRM6-12-C/630DL means load switch cabinet, rated voltage 12kV, rated current 630A, right extension, left cable in and out.
2. QY-SRM6-12-CF/630IR represents the combination of load switch unit and fuse combination unit, the busbar voltage is 12kV, the busbar current is 630A, the left side is extended, and the right cable is in and out.

QY-SRM16

Fully insulated inflatable ring switch equipment

Technical parameter

Item	Unit	C module	F module	V module		CB module	
		Composite switch	Combination appliances	vacuum switch	Isolation/Earth Switch	vacuum circuit breaker	Isolation/Earth Switch
Rated voltage	kV	12	12	12	12	12	12
Rated frequency	Hz	50	50	50	50	50	50
Power frequency withstand voltage (phase/port)	kV	42/48	42/48	42/48	42/48	42/48	42/48
Lightning impulse withstand voltage	kV	75/85	75/85	75/85	75/85	75/85	75/85
Rated current	A	630	Note 1)	630		1250/630	1250/630
Rated closed-loop breaking current	A	630					
Rated cable charging breaking current	A	135/135					
Rated short-circuit making current (peak value)	A	50	80				
Rated peak withstand current	kA	50					
Rated short-time withstand current	kA/3s	20					
Rated short-circuit breaking current	kA		31.5	20		25	25
Rated transfer current	A		1750				
Equipped with the maximum current of the fuse	A	-	125				
Loop resistance	-n	≤300	≤600				
Mechanical life	time	5000	3000	5000	2000	5000	5000

Installation dimension drawing

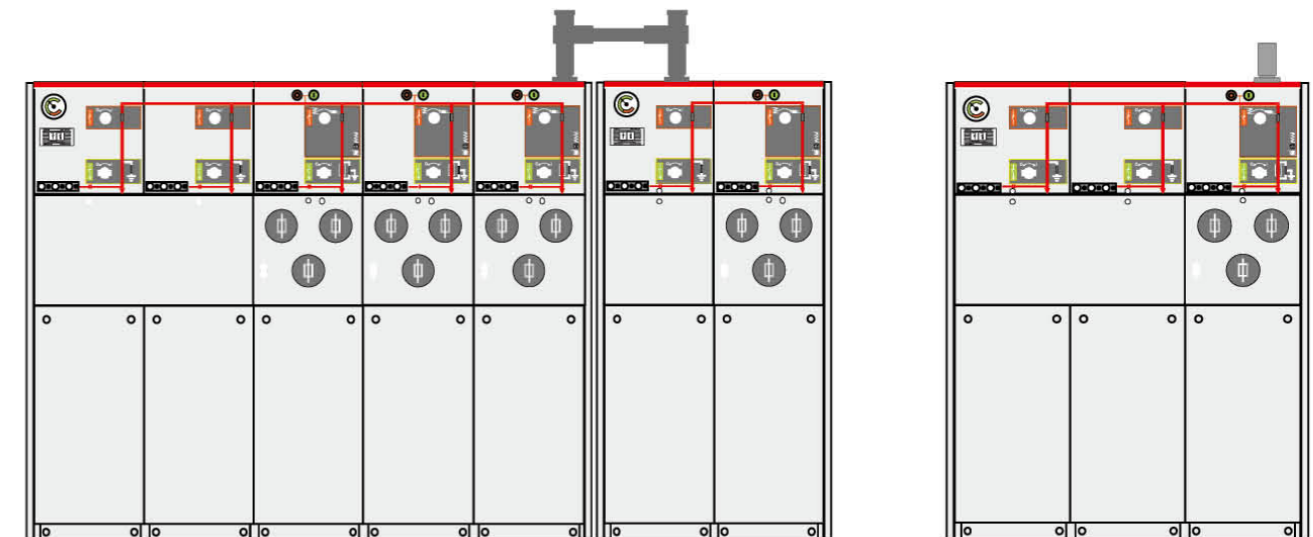

(YQ)XGN15

AC metal enclosed ring network switchgear



Overview

(QY)XGN15 series box-type fixed AC metal-enclosed switchgear is a compact and expandable metal-enclosed ring that uses FLN-12 SF6 load switch as the main switch and the whole cabinet adopts air-insulated, suitable for distribution automation. network switchgear. It has the characteristics of simple structure, flexible operation, reliable interlocking and convenient installation. It can provide satisfactory technical solutions for various applications and different user requirements.

The main switch of (QY)XGN15 series box-type fixed AC metal-enclosed switchgear adopts the FLN36-12 type, FLN48-12 type SF6 load switch produced by our company, or the SFG type SF6 load switch produced by ABB company. It needs to be equipped with VS1 type, VD4/S type, ISM type vacuum circuit breaker or HD4/55 type SF6 circuit breaker. The load switch and circuit breaker can be operated manually or electrically, and the power distribution automation function can be realized after selecting the electric operating mechanism, PT, CT, FTU and communication device.

Model meaning

QY HX G N 15 - 12 - FZ R
① ② ③ ④ ⑤ ⑥ ⑦ ⑧

①	Enterprise code
②	Box
③	Stationary
④	Indoor type
⑤	Design Number
⑥	Voltage level
⑦	Vacuum load switch (without Z is a compressed air load switch)
⑧	Fuse Combination Appliances

Conditions of Use

- >Ambient temperature: upper limit +40°C, lower limit -15°C.
- >The maximum altitude of the equipment installation site: 1000m;
- >Environmental humidity: daily average relative humidity ≤95%, monthly average relative humidity ≤90%;
- >Earthquake heat does not exceed 8 degrees;
- >The surrounding air should not be significantly polluted by corrosive or combustible gas, water vapor, etc.
- >No serious contamination and frequent violent vibration.

(YQ)XGN15

AC metal enclosed ring network switchgear

Technical parameter

Serial number	Project	Unit	Parameter
1	Rated voltage	kV	12
2	Rated frequency	Hz	50
3	Main busbar rated current	A	630
4	Rated short-time withstand current/duration of main loop and ground loop	kA/s	20/3, 20/20
5	Rated peak withstand current of main loop and ground loop	kA	50
6	Rated short-circuit making current of main loop and ground loop	kA	50
7	Load switch full capacity breaking times	次	100
8	Fuse breaking current	kA	31.5, 40, 50
9	Mechanical life	次	2000
10	1min working withstand voltage (RMS) time, ground/isolation break	kV	42/48
11	Lightning impulse withstand voltage (peak) phase-to-phase, to ground/isolation fracture	kV	75/85
12	Secondary circuit 1min working frequency withstand voltage	kV	2

Installation dimension drawing

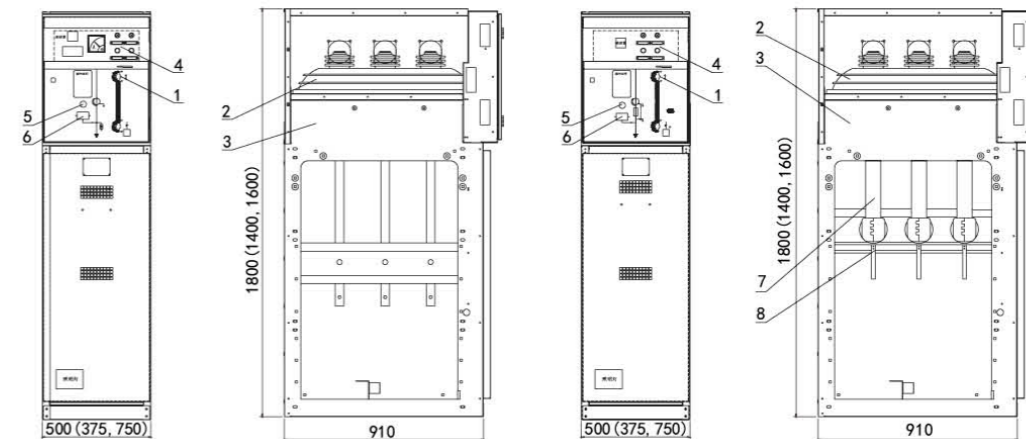

Schematic diagram of the structure of the incoming cabinet

Outlet cabinet structure diagram

1. Operating mechanism 2. Load switch 3. Cabinet 4. Instrument room 5. SF6 voltmeter 6. High voltage live display 7. Fuse 8. Lower grounding switch

Dimensions

	Size	Conditions of Use
Height H(mm)	1400	Suitable for single core cable
	1600	Suitable for single core cable
	1800	Suitable for three-core cables
WidthW(mm)	375	incoming, outgoing
	500	
Depth D(mm)	750	
	910	

QY-GTXGN-12

Solid fully insulated closed ring network switchgear



Overview

GTXGN-12 series solid fully insulated closed ring network switchgear is a fully insulated, fully sealed, maintenance-free solid insulation vacuum switchgear. All high-voltage live parts are cast and molded with epoxy resin materials with excellent insulating properties, which organically combine the vacuum interrupter, the main conductive circuit, and the insulating support into a whole, and the functional units are connected by fully insulated solid bus bars. Therefore, the entire switchgear is not affected by the external environment, which ensures the reliability of equipment operation and the safety of operators.

The ring network cabinet has the characteristics of simple structure, flexible operation, reliable interlocking, convenient installation, etc. It is suitable for 50Hz, 12kV power system, and is widely used in industrial and civil cable ring network and distribution network terminal projects. It is especially suitable for power distribution in urban residential areas, small substations, switching stations, cable branch boxes, box-type substations, industrial and mining enterprises, shopping malls, airports, subways, wind power generation, hospitals, stadiums, railways, tunnels and other places use.

Because the product has the advantages of full insulation, full sealing and full shielding, it is especially suitable for use in areas with harsh environments such as high altitude, high temperature, damp heat, severe cold, and serious pollution.

Model meaning

QY-GTXGN - 12 / □ - □ - □
① ② ③ ④ ⑤

①	Enterprise product code
②	Rated voltage (kV)
③	Product Solutions (C.V.F)
④	Rated current (A)
⑤	Rated short-time withstand current (kA)

Scope of application

- >Suitable for indoor or outdoor use.
 - >Ambient air temperature: indoor -10°C ~ +25°C, outdoor -60°C ~ +60°C.
 - >Air relative humidity: the daily average is not more than 95%, and the monthly average is not more than 90%.
 - >The altitude is not more than 3000m.
 - >The surrounding air should not be significantly polluted by dust, water vapor, salt spray, corrosive gas or flammable gas; the outdoor type can be used in harsh environmental conditions.
 - >There is no violent vibration at the installation site, and the earthquake degree does not exceed 8 degrees.
- When the above-mentioned use environment conditions cannot meet the use requirements, the user shall negotiate with the manufacture

QY-GTXGN-12

Solid fully insulated closed ring network switchgear

Technical parameter

Serial number	Project	Unit	Parameters	
1	Rated voltage	kV	12	
2	Rated current	A	630	
3	Rated short-time withstand current (4s)	kA	25	
4	Rated peak withstand current	kA	50	
5	Rated short-circuit making current (peak value)	kA	50	
6	Rated active load breaking current	A	630	
7	Rated closed-loop breaking current	A	630	
8	Rated cable charging breaking current	A	10	
9	Rated breaking transfer current of combination appliance	A	3700	
10	1min power frequency withstand voltage	Phase to Phase Vacuum Fracture	kV	42
		isolation fracture	kV	48
11	Lightning impulse withstand voltage	Phase to Phase Vacuum Fracture	kV	75
		isolation fracture	kV	85
12	Mechanical life	breaker	Second-rate	10000
		Isolation knife, grounding knife	Second-rate	3000
13	Rated short-time withstand current (4s)			IP4X
14	Rated peak withstand current (1p)			IP4X
15	Rated short-circuit making current (peak value) (1ma)	pC		≤20(measured under 1.2Ur)

Installation dimension drawing

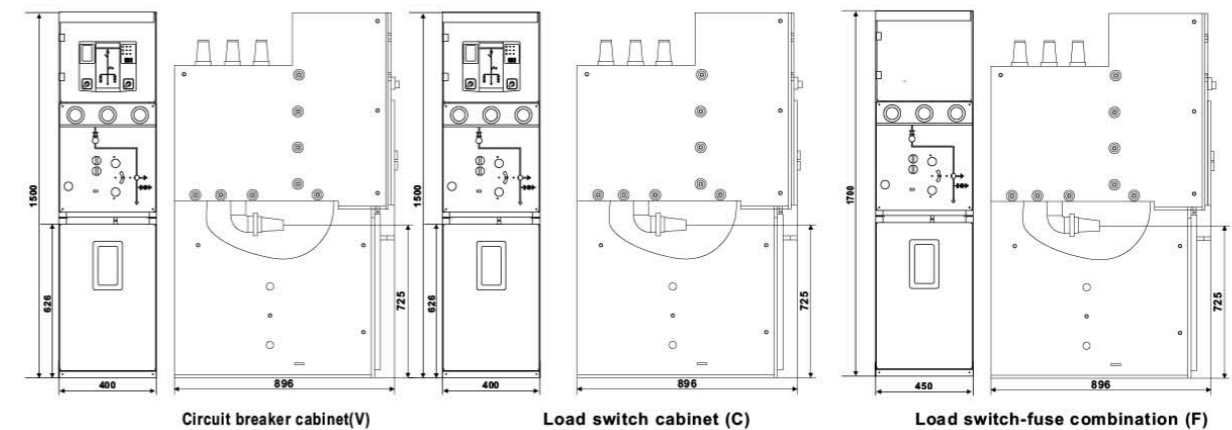

QYAir-12/T630-25

Environmentally friendly gas-insulated metal-enclosed switchgear



Overview

QYAir-12series environmental protection gas-insulated metal-enclosed switchgear adopts vacuum interrupter for arc extinguishing, environmental protection gas is the main insulating medium, a small amount of solid insulation support, the main circuit has no encapsulation, and the normal operation is zero gauge pressure or micrometer. Positive pressure (air pressure of the air box is less than 0.02MPa), and the relative ground and phase-to-phase insulation capabilities meet the air insulation requirements of zero gauge pressure distribution switchgear.

Environmental protection gas insulated metal-enclosed switchgear is the most commonly used three-phase AC intelligent environmental protection gas insulation cabinet, and is widely used in various complete switchgear. With the development of the market, the demand will also increase; the market potential has yet to be developed. At the same time, because the product integrates the functions of data acquisition and control, data processing and storage, on-line monitoring of switchgear and advanced analysis, it can carry out online intelligent monitoring and management of the distribution network, so that the distribution network can operate in a safe, reliable and The best state of high quality and efficiency realizes the remote monitoring, control and management of the power distribution network of the power system, and realizes the needs of power grid optimization, electricity safety, power management, energy saving and consumption reduction; the system can also be widely used in transportation, factories, etc. , hospitals, schools, buildings, residential quarters and commercial office buildings and other intelligent power distribution fields.

Model meaning

QY Air- □ □ / □ □ - □
① ② ③ ④ ⑤ ⑥ ⑦

①	Enterprise code
②	Product model
③	Rated voltage
④	Cabinet Module*
⑤	Operation method
⑥	Rated current
⑦	Breaking current

Remark:

*HB-12 series general cabinet modules include:

C—Load switch module

V—Vacuum circuit breaker module

F—Load switch-fuse combination electrical module

Conditions of Use

>Maximum temperature: +40°C;

>Minimum temperature: -25°C;

> 24-hour average temperature: ≤35°C;

>Maximum average relative humidity: 24-hour average ≤95%, monthly average: ≤90%;

>Altitude: ≤ 2000m, should be specified when ordering;

>For special operating conditions beyond the normal use environment, please consult with our company in advance.

QYAir-12/T630-25

Environmentally friendly gas-insulated metal-enclosed switchgear

Technical parameter

Serial number	Project	V module			
		C module load switch	F module Combination appliances	vacuum circuit breaker	isolation/Earth Switch
1	Rated voltage	12			
2	1min power frequency withstand voltage	42/48			
3	Lightning impulse withstand voltage	75/85			
4	Rated current	630	125*	630	630
5	breaking capacity				
	Closed-loop breaking current	630			
	Cable charging breaking current	135			
	5% active load breaking current	31.5			
	Ground fault interrupting current	200			
6	Rated transfer current		1500		
7	Select the maximum current of the fuse		125		
8	Short-circuit making current	63	80*	25	
9	Short-time withstand current	25		25	25
10	short circuit duration	4		4	4
11	Mechanical life	5000	5000	10000	3000
12	gas pressure	0.025 (20°C)			
13	Annual leak rate	≤0.05%			
14	Arc extinguishing method	vacuum arc extinguishing			
15	Protection class	IP67/3X (air box/enclosure)			

Installation dimension drawing

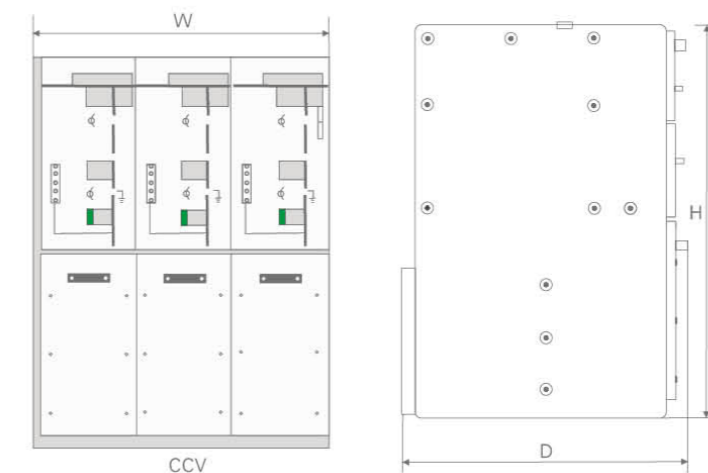

	1-way	2-way	3-way	4-way	5-way
W(mm)	371	696	1021	1346	1671
H(mm)	1336				
D(mm)	850(total 935)				

DFW-12/24

Series telescopic branch box



Overview

The European-style cable distribution box is a cable engineering equipment widely used in the power distribution network system in recent years. Significant advantages such as no need for large-span crossover. The cable glands it uses conform to the DIN47636 standard. Generally use the rated current 630A bolted connection cable joint.

Model meaning

DFW □ - □ □
① ② ③ ④

①	Cable distribution box
②	Voltage level
③	Number of circuits (total number of incoming and outgoing lines in one phase)
④	A is with arrester, the default is without

Conditions of Use

- > Ambient temperature: maximum temperature: +40°C, minimum temperature -30°C
- > Wind speed: quite 34m/s (not more than 700Pa)
- > Humidity: The average daily relative humidity is not more than 95%; the average monthly relative humidity is not more than 95%
- > Shockproof: the horizontal acceleration is not more than 0.4m/s², and the vertical acceleration is not more than 0.15m/s²
- > Installation site inclination: no more than 3°
- > Installation environment: The surrounding air should not be significantly polluted by corrosive, flammable gas, water vapor, etc., and there should be no violent vibration at the installation site.

When ordering this product beyond the above conditions, please consult with our company.

Technical parameter

Serial number	project	Parameter
1	Rated current	12kV
2	Rated current	630A
3	Dynamic stable current	50kA/0.3s
4	Thermally stable current	20kA/3s
5	1 minute power frequency withstand voltage	42kV
6	15 minutes DC withstand voltage	52kV
7	Lightning impulse withstand voltage	105kV
8	Cabinet protection level	IP33

DFW-12/24

Series telescopic branch box

Installation dimension drawing

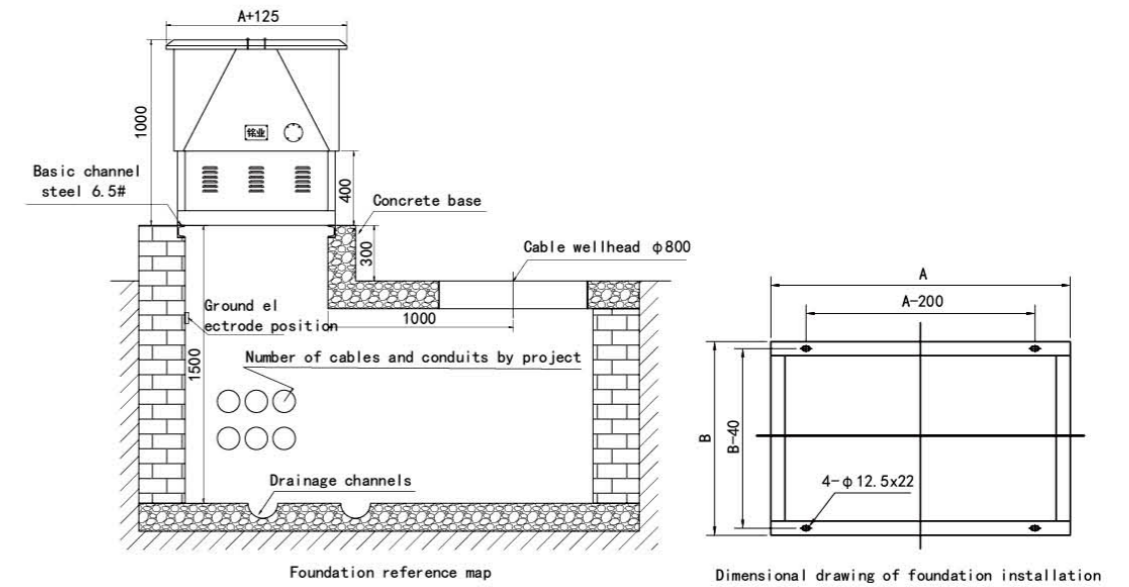

Number of branches	2	3-4	5-6	7-8	9-12
A	550	850	1090	850	1090
B	550	550	550	650	650





Overview

With the intensification of urban densification, some original civil construction openings and closings have been restricted by land and urban planning, so a more advanced and practical outdoor intelligent opening and closing (outdoor ring main unit) has emerged. This opening and closing station does not require civil construction and occupies less floor space. The configuration is very flexible and the power supply mode is more reliable. The construction, installation and commissioning time is greatly shortened, and the overall cost is reduced.

With the development of modern industry, the degree of automation and intelligence of electrical control equipment is getting higher and higher. Using modern electronic technology, sensor technology, communication technology, and computer network technology, the monitoring, protection, and The integration of control and measurement to achieve good management has become an inevitable trend and development direction.

Ring net box (opening and closing station) measures 12/24kV switchgear, circuit breaker, load switch, current and voltage transformer, 12/24kV power supply PT, opening and closing station FTU, RTU, communication control terminal (CCU), 12/24kV And automatic meter reading, USP power supply and indicating instruments are installed and debugged into a movable, sealed and moisture-proof stainless steel box, so as to realize the integration of primary and secondary systems in the urban distribution network, modularization of assembly, shortening It shortens the construction period and greatly improves the reliability of urban power grid operation.

Model meaning

DFW □ - 12 / 630 - □ □
① ② ③ ④ ⑤ ⑥

①	Ring cage (opening and closing)
②	Design Number
③	Rated voltage (kV)
④	Rated current (A)
⑤	Number of incoming circuits
⑥	Number of outgoing circuits

Conditions of Use

- > Altitude: ≤ 2000m, should be specified when ordering;
- > Maximum ambient temperature: +40 °C;
- > Minimum ambient temperature: -25 °C;
- > Maximum daily temperature difference: 25K;
- > Indoor relative humidity: daily average ≤ 95%, monthly average ≤ 90%;
- > Earthquake resistance: the ground horizontal acceleration is 0.2g; the vertical acceleration is 0.1g at the same time. Resonance, sine and beat wave test methods are used; 5 times of excitation, 5 waves each time, each time interval 2s, the safety number is not less than 1.67;
- > The installation site should be free from gas vapors, chemical deposits, dust, dirt and other explosive and corrosive media that seriously affect the insulation of the load switch;
- > For ungrounded systems and 10kV systems grounded through small resistances or via arc suppression coils.

Technical parameter

Serial number	Project	Unit	Load switch cabinet	Combined electrical cabinet	
1	Rated voltage	kV	12		
2	Rated frequency	Hz	50		
3	Rated current	A	630	200	
4	Rated short-time withstand current (RMS)	kA	20kA	20kA	
5	Rated short circuit duration	s	3s	3s	
6	Rated peak withstand current	kA	50 / 63		
7	Closed-loop breaking current	A	630		
8	Rated cable charging breaking current	A	25		
9	Rated no-load transformer breaking current	A	16		
10	Rated breaking transfer current	A	1750		
11	Expected short-circuit breaking current of fuse (RMS)	kA	63		
12	Earthing switch short-time withstand current/duration	kA	25kA/1s		
13	Rated current breaking times	Second-rate	≥200		
14	Mechanical life	Second-rate	≥2000		
15	Annual leakage rate of SF6 gas		Not more than 1%		
16	Rated absolute edgelevel	1min power frequency withstand voltage (RMS)	Between fractures	kV	48/79118
			Alternate	kV	42/65/95
			Relatively	kV	42/65/95
		Lightning impulse withstand voltage (peak)	Between fractures	kV	85/145/215
			Alternate	kV	75/125/185
			Relatively	kV	75/125/185
17	Spring operating mechanism		Manual, can be upgraded to electric		
18	Operating voltage	V	DC 48V/AC 220V		
19	External insulation creepage distance	mm/kV	≥20		
20	Different period of opening	ms	< 5		
21	Closing aperiodicity	ms	< 5		
22	Main circuit resistance	uΩ	< 140		
23	Cabinet enclosure protection class		IP4X		



Overview

This product fully complies with GB17467 "high voltage and low voltage prefabricated substation" standard. It is suitable for urban public power distribution, street lamp power distribution, industrial and mining enterprises, urban buildings, residential quarters, oil field terminals, hotels, parks and construction sites, etc. It can realize ring network or terminal power supply mode.

Model meaning

YB □ □ □ / □ - □
① ② ③ ④ ⑤ ⑥

①	Prefabricated Substation
②	Structural features: P-character shape; M-mesh shape
③	Design serial number
④	Rated voltage of high voltage side (kV)
⑤	Rated voltage of low voltage side (kV)
⑥	Transformer rated capacity (kVA)

Conditions of Use

The user needs to provide the following information if ordering:

- >Altitude: ≤1000m;
- >Ambient temperature: -25°C~+40°C;
- >Relative humidity: the daily average is not more than 95%, the monthly average is not more than 90%;
- >Shockproof level: horizontal acceleration 0.4m/s², vertical acceleration 0.15m/s²;
- >The installation site has no severe impact, serious pollution and chemical corrosion, no conductive dust and explosion hazard. When the requirements of normal use conditions cannot be met, please consult with our company to solve the problem.



Technical parameter

Serial number	Project	Unit	High voltage electrical appliances	Transformer	Low voltage electrical appliances
1	Rated voltage	kV	6/10	6/0.4 10/0.4	0.4
2	Rated Capacity	kVA		50~1600	
3	Rated current	A	200, 400, 630		100~3200
4	Rated short-circuit breaking current	A	Load switch 400-630		15~63kA
		kA	Combination switch depends on fuse		
5	Rated short-time withstand current	kA	16, 20 (4s)		15(1s)
				30(1s)	
6	Rated peak withstand current	kA	31.5, 50		30
					63
7	Power frequency withstand voltage (1min)	kV	Phase and Phase 32/42	25/35 (oil immersion)	≤0.3,2
			Isolation Fracture 36/48	20/28(dry)	>0.3,2.5
8	Lightning impulse withstand voltage (peak)	kV	Phase and Phase 60/75	60/75	
			Isolation Fracture 70/85		
9	Cabinet protection level			IP32	
10	noise level	db		55	
11	Executive standard		GB/T 17467 "High-voltage and low-voltage prefabricated substations"		
			DL/T537 "Technical Conditions for Ordering 6-35kV Box-type Substation"		

Installation dimension drawing

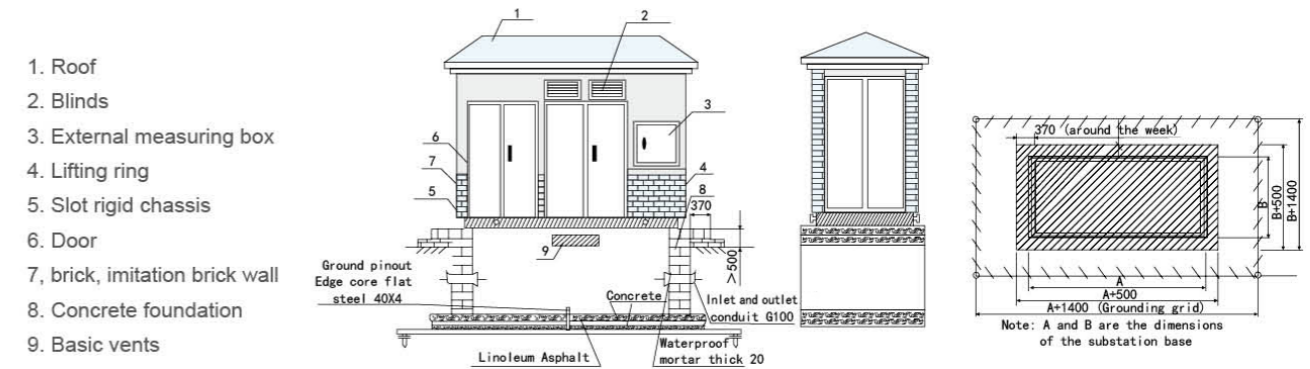

Download Google

The user needs to provide the following information if ordering:

- >Model, capacity, quantity, color, dimension, shell material;
- >Transformer model, performance, connection group, tap range and impedance requirements;
- >Primary wiring scheme, component models, specifications and requirements on the high and low voltage sides;
- >Transformer oil (25#, 45#, high ignition point oil);
- >Network configuration requirements for box-type substations by intelligent power management network or property management;
- >Use environmental requirements.

ZGS13-12/0.4

Combined American prefabricated substation



Overview

This product has the characteristics of small size, easy installation and maintenance, low noise, low loss, anti-theft, full protection, and strong overload capacity. It is suitable for new residential areas, green belts, parks, station hotels, construction sites, airports and other places.

ZGS13-12/0.4 series prefabricated substations (American style), suitable for 10kV ring network power supply, dual power supply or terminal power supply system, as substation, metering, compensation control and protection devices. This product complies with the following standards: GB17467 "High Voltage and Low Voltage Prefabricated Substation" DL/T537 "High Voltage and Low Voltage Prefabricated Box Substation Selection Guide".

Model meaning

ZG S 13 - 12/0.4 (□) □ □

① ② ③ ④ ⑤ ⑥ ⑦

①	pre-installed
②	Substation
③	Design Number
④	Rated voltage
⑤	High-voltage switchgear is equipped with main switch category F-load switch; F-R-load switch + fuse
⑥	High-voltage switchgear with operating mechanism category T-spring mechanism; s-manual mechanism
⑦	Transformer rated capacity (kVA)

Conditions of Use

- >The altitude does not exceed 1000m;
- >Ambient temperature: -35°C~+40°C;
- >Relative humidity: the daily average is not more than 95%, the monthly average is not more than 90%;
- >Installation place: no fire, explosion hazard, chemical corrosive gas and well-ventilated place, the ground inclination angle is not more than 3°.



ZGS13-12/0.4

Combined American prefabricated substation

Technical parameter

Serial number	Project	Unit	parameter
1	Rated voltage	kV	10/0.4 (high pressure/low pressure)
2	Maximum working voltage	kV	12 (high pressure side)
3	Rated frequency	Hz	50
4	Rated Capacity	kVA	50-800
5	1 minute power frequency withstand voltage	k	35
6	Lightning impulse voltage	kV	75
7	cooling method		Oil-immersed self-cooling
8	High voltage backup fuse breaking current	kA	50
9	Plug-in fuse breaking current	kA	25
10	ambient temperature	°C	-35~+40
11	Coil allowable temperature rise	°C	65
12	No-load voltage regulation		±5% or ±2×2.5%
13	voice level	db	50
14	Protection class		IP43

Installation dimension drawing

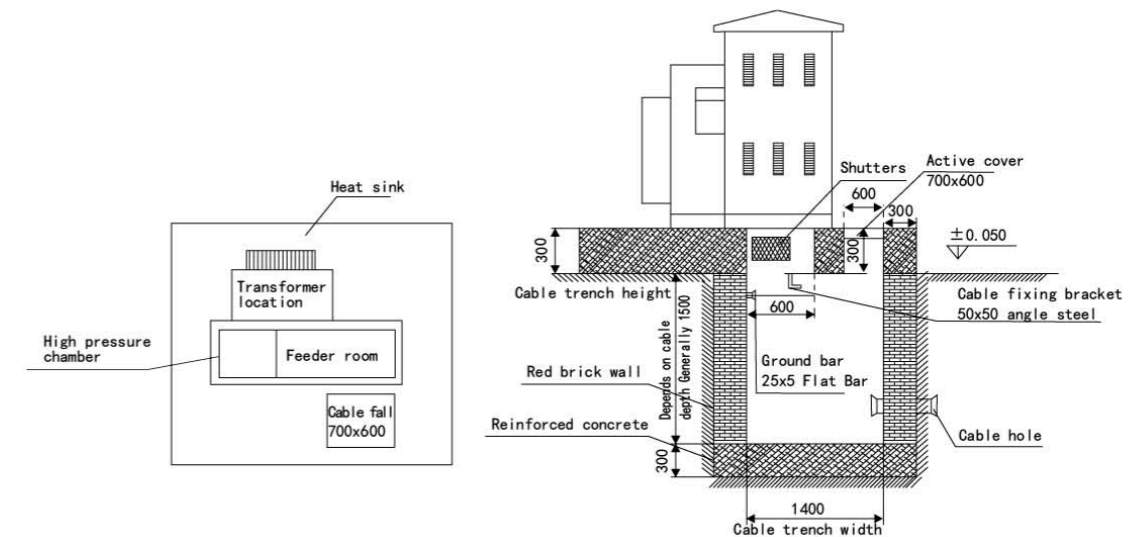

Download Google

- >Product operation site and special requirements;
- >Provide the product order drawing, the wiring diagram should be included in the order drawing, and the transformer capacity, the model and specification of the main components, the distribution branch circuit and the capacity should be indicated;
- >When the electric energy metering and reactive power automatic compensation device needs to be configured, the configuration requirements of the metering watt-hour meter and the transformer should be provided, and the capacity of the compensation capacitor should be indicated;
- > Indicate the requirements for product surface treatment;
- >Please specify the terminal type or ring network type when ordering the combined transformer.

10~35kV

Modular prefabricated cabin substation



Overview

The 10~35kV modular prefabricated cabin substation is a combination of electrical units such as transformers, multi-circuit high-voltage switch systems, reactive power compensation devices, insulated busbars, substation integrated automation systems, communications, telecontrol, metering, and DC power supplies. , reliability, easy maintenance, and integration principles are integrated and installed in a heat-insulating, fire-proof, anti-theft, moisture-proof, small animal-proof, five-sided ventilation, fully enclosed, movable steel structure box. It is suitable for the construction and transformation of small and medium-sized substations (distribution) substations of 10Kv~35Kv integrated substations in cities and rural areas, and substations in factories and mines. Because it penetrates into the load center, reduces the power supply radius and improves the power supply quality, it is especially suitable for the transformation of urban distribution network, and is known as the "target mode of substation construction in the 21st century".

It is in line with the State Grid Corporation's standards, the new rural electrification standard system and the electrification implementation outline. It truly realizes the leap from building a substation in the traditional way to buying an integrated substation!

Conditions of Use

- > Use production place: outdoor;
- > Altitude: $\leq 3000\text{m}$;
- > Ambient temperature: $-45^{\circ}\text{C} \sim +45^{\circ}\text{C}$, the highest daily average temperature does not exceed 35°C ;
- > Wind speed: $\leq 35\text{m/s}$;
- > Ground inclination: $\leq 5^{\circ}$;
- > Sun radiation: $\leq 1000\text{W/m}^2$;
- > Relative humidity: daily average $\leq 95\%$, monthly average $\leq 90\%$;
- > Ice thickness: 10mm ;
- > Earthquake cracking degree: no more than 8;
- > Foundation: characteristic value of foundation bearing capacity $F_{ak} = 150\text{kpa}$, no groundwater influence;
- > The installation site is free of explosion hazard, fire, chemical corrosion and severe vibration.
- > Please contact our technical department if the conditions of use are exceeded.

Features

- > The standard design area of the 10~35kV modular prefabricated cabin substation is only 230 square meters. Compared with the conventional substation, it can save 60%~80% of the floor space, which is in line with the national land saving policy.
- > Most of the electrical equipment used is produced by our company, which effectively reduces the product cost; the electrical equipment is installed indoors and will not be affected by external factors, so the operation and maintenance costs are greatly reduced; the all-metal structural shell is used, and all components All have been treated with anti-corrosion, the maintenance amount is very small, the service life is long, and the energy consumption is low;

10~35kV

Modular prefabricated cabin substation

> An integrated construction scheme is adopted. The conventional design scheme has been constructed many times. The design and construction are carried out according to the ready-made scheme, and the amount of local adjustment is very small. The functional modules such as: incoming module, outgoing module, transformer and The protection module only needs to be called directly, and the production cycle is relatively short. The construction period is shortened to 3 months, while the construction period of a conventional substation takes at least 1 year. It is really better to build a station than to buy a station.

> The prefabricated integrated substation has almost no impact on the environment, because the initial construction amount is very small, except for the structure, all construction work is carried out indoors, and the noise and electromagnetic radiation during operation are shielded in the metal layer. Moreover, the shell structure is made of metal components, and its service life is much longer than that of brick-concrete and cement structures, and all components can be recycled and reused.

Solution

Using reliable electrical equipment, combined with the system integration technology of outdoor box-type substation cabinets and the original prefabricated cabin manufacturing technology, the substation is divided into modules according to functions, and standardized design, factory production, and modular construction are carried out. Different modules are selected for different configurations to realize building block combination, which has the characteristics of small footprint, short station construction period, high safety and reliability, and beautiful appearance.

Modular design, the whole station is divided into six types of distribution modules:

- > 35kV prefabricated cabin GIS combined electrical module;
- > 10kV prefabricated cabin switch station module;
- > Prefabricated cabin type secondary combined equipment module;
- > Prefabricated cabin transformer modules;
- > 10kV prefabricated cabin grounding arc suppression coil;
- > 10kV prefabricated cabin reactive power compensation system.

Compact substation layout:

- > Greatly reduce the floor space;
- > Original three-dimensional arrangement of prefabricated cabins;
- > 35kV prefabricated cabin GIS combined electrical appliances are placed on the top to save space;
- > The prefabricated cabin type 10kV switch station and the prefabricated cabin of the secondary combined equipment are arranged in a zigzag shape at the bottom of the finished product;
- > Symmetrical arrangement of prefabricated cabin transformers;
- > The fire escape is arranged between the three-dimensional substation and the transformer;
- > Flexible building block construction according to the site topography;
- > 10kV wiring mode can be flexibly designed according to user needs to achieve maintenance-free;

The >10kV system is a single busbar segment, and high-end and high-end fixed switchgear such as Siemens and ABB are selected to achieve maintenance-free;

- > Adopt a fixed compensation system, and configure the grounding variable arc suppression coil module according to the needs of the station construction;
- > Maintenance-free, unattended, intelligently managed and controlled substations;
- > The artistic appearance is harmonious and harmonious with the urban environment;
- > The prefabricated cabin adopts advanced technologies such as double-layer steel plate foaming technology, six-layer anti-corrosion technology, and broken bridge insulation, which fully meets the 60-year service life requirements of the main building of the substation;
- > Micro-positive pressure dust-proof technology, box thermal insulation technology and intelligent environmental control technology create a constant temperature, constant humidity and dust-free operating environment for electrical equipment, surpassing traditional indoor substations;
- > The external dimensions of each prefabricated cabin module adopt standardized modules, which can meet the transportation requirements without exceeding the limit.

KYN61-40.5

Armored removable AC metal-enclosed switchgear



Overview

KYN61-40.5 armored removable AC metal-enclosed switchgear (hereinafter referred to as switchgear) is a complete set of indoor power distribution devices with three-phase AC volume of 50Hz and rated voltage of 40.5kV. As power plants, substations and industrial and mining enterprises to receive and distribute electrical energy, it can control, protect and monitor circuits, and can also be used in places where frequent operations are performed.

The switchgear complies with GB3906-2006 "3~35kV AC metal-enclosed switchgear", GB/T11022-1999 "Common technical requirements for high-voltage switchgear and control equipment standards" and DL/T 404-2007 "3.6kV~40.5kV AC Metal-enclosed switchgear and controlgear and other standards."

Model meaning

K Y N 61 - 40.5 □ / □ □
① ② ③ ④ ⑤ ⑥ ⑦ ⑧

①	Metal Armored Switchgear
②	Removable
③	Indoor
④	Design Number
⑤	Rated voltage (kV)
⑥	Type of circuit breaker: Z-vacuum; SF6-sulfur hexafluoride
⑦	Rated current
⑧	Rated short-circuit breaking current (kA)

Conditions of Use

>Ambient temperature: the upper limit is +40°C, and the average value measured within 24 hours does not exceed 35°C, and the lower limit is -10°C;

>Altitude: the altitude should not exceed 2000m, which should be specified when ordering;

> Relative humidity: daily average does not exceed 95%, monthly average does not exceed 90%;

> Earthquake intensity: no more than 8 degrees;

>Water vapor pressure: the daily average does not exceed 2.2kPa, and the monthly average does not exceed 1.8kPa;

> Surrounding environment: place without fire, explosion hazard, serious pollution, chemical corrosion and severe vibration.

KYN61-40.5

Armored removable AC metal-enclosed switchgear

Technical parameter

Serial number	Project	Unit	Parameter
1	Rated voltage	kV	40.5
2	Rated current	A	1250 1600 2000
3	Rated frequency	Hz	50
4	Rated short-time withstand current	kA	20 25 31.5
5	Rated peak withstand current	kA	50 63 80
6	Rated power frequency withstand voltage	kV	95/1min
7	Rated lightning impulse withstand voltage	kV	185
8	Rated short circuit duration	s	4
9	Protection class		IP3X

Installation dimension drawing

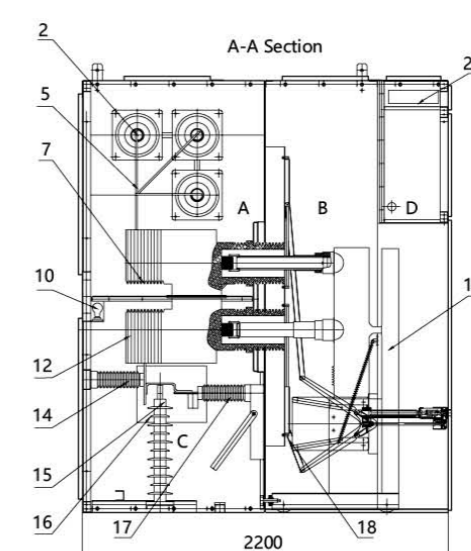
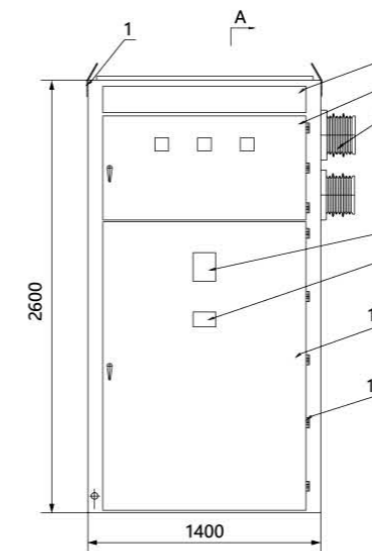

- A. Bus room
- B. Handcart room
- C. Cable room
- D. Relay instrument room
- 1. Lifting ring
- 2. Main bus
- 3. Small busbar chamber cover ring
- 4. Instrument room door
- 5. Branch bus
- 6. Bus bushing
- 7. Hornworm head box
- 8. Analog mother coil
- 9. Nameplate
- 10. Lighting
- 11. Handcart door
- 12. Current transformer
- 13. Hinges
- 14. Insulators
- 15. Zinc oxide arrester
- 16. Insulation partition
- 17. Grounding switch
- 18. Valve assembly
- 19. Vacuum circuit breaker handcart
- 20. Small bus bar terminal room

Download Google

The user needs to provide the following information if ordering:

>Main circuit scheme number, purpose, single-line system diagram, arrangement diagram and layout diagram of power distribution room, etc.;

>Auxiliary circuit wiring schematic diagram and terminal arrangement diagram;

>Model, specification and quantity of electrical components in switchgear;

> Requirements for control, measurement and protection functions of switchgear and other locking and automatic devices;

>If bus bridge connection is required between switchgear or incoming cabinet, specific requirements data such as rated current carrying capacity of bus bridge, span of bus bridge and height from ground should be provided;

>When accessories and spare parts are needed, the type and quantity should be proposed;

>The switchgear is used in special environmental conditions and should be specified in detail when ordering.

KYN28-12

Armored removable AC metal-enclosed switchgear



Overview

KYN28-12 armored removable AC metal-enclosed switchgear is suitable for three-phase AC rated voltage 12kV, rated frequency 50Hz power system, used to receive and distribute electric energy and control, protect and monitor circuits.

This product complies with GB3906 "3~35kV AC metal-enclosed switchgear", GB/T11022 "Common technical requirements for high-voltage switchgear and control equipment standards", IEC60298 "Rated voltage above 1kV and below AC metal-enclosed switchgear and control equipment", DL/T404 "Indoor AC High Voltage Switchgear Ordering Technical Conditions" standard requirements.

Model meaning

K Y N 28 - 12 (Z) / T □ □ □
 ① ② ③ ④ ⑤ ⑥ ⑦ ⑧ ⑨ ⑩

①	High voltage armored switchgear
②	Removable
③	Indoor type
④	Design serial number
⑤	Rated voltage
⑥	Vacuum circuit breaker
⑦	spring operating mechanism
⑧	Rated current
⑨	Rated short-circuit breaking current
⑩	One-time plan number

Conditions of Use

- > Surrounding air temperature upper limit +40°C lower limit -15°C;
- >The maximum altitude of the equipment installation site: 2000m, which should be specified when ordering;
- >Environmental humidity Daily average relative humidity ≤95% Monthly average relative humidity ≤90%;
- > Earthquake intensity does not exceed 8 degrees;
- >The surrounding air should not be significantly polluted by corrosive or flammable gas, water vapor, etc.;
- >No serious contamination and frequent violent vibration.

KYN28-12

Armored removable AC metal-enclosed switchgear

Technical parameter

Serial number	Project	Unit	Parameter	
1	Rated voltage	kV	12	
2	Rated insulation level	Powerfrequency withstand voltage	kV	Alternate and ground: 42; Fracture: 48
		Lightning strike	kV	Alternate and ground: 75; Fracture: 85
3	Rated frequency	Hz	50	
4	Circuit breaker rated current	A	630, 1250, ,1600,2000,2500,3150,4000	
5	Switchgear rated current	A	630, 1250, ,1600,2000,2500,3150,4000	
6	Rated short-circuit breaking current	kA	20,25,31.5,40	
7	Rated short-time withstand current of main circuit	kA/4s	20,25,31.5,40	
8	Protection class		IP4X	

Installation dimension drawing

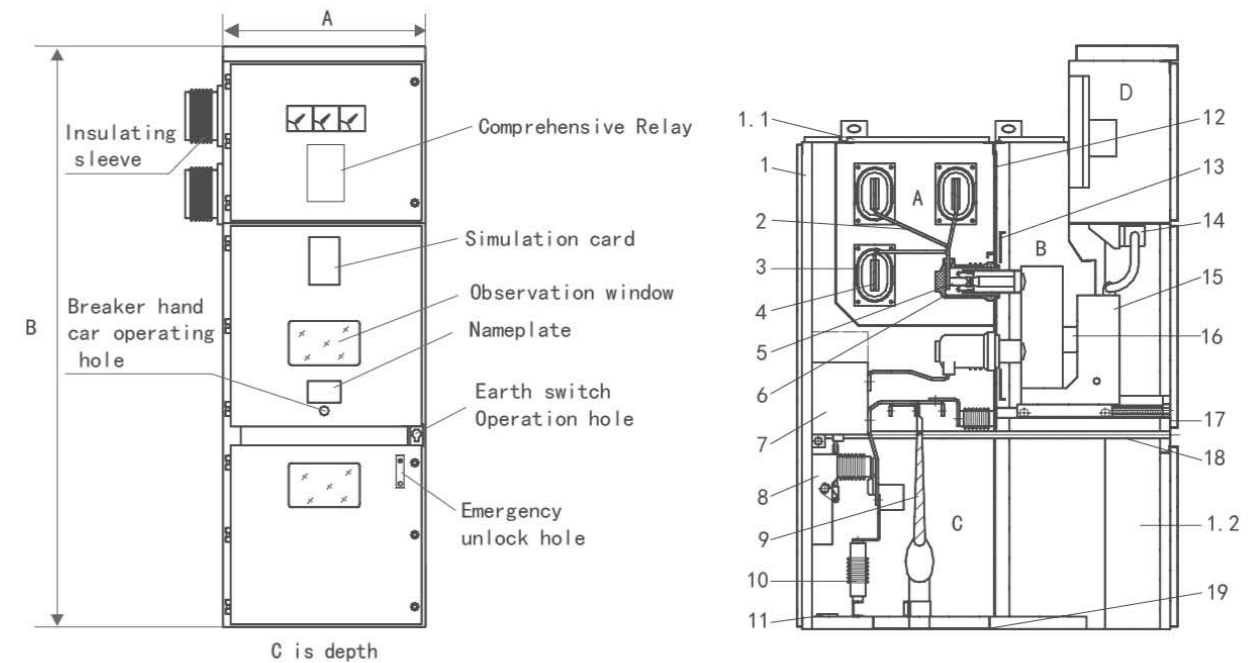

- | | | |
|----------------------------------|--------------------------|--|
| A. Bus room | 3. Busbar bushing | 11. Ground bus |
| B. Circuit breaker handcart room | 4. Main bus | 12. Removable bulkhead |
| C. Cable room | 5. Static contact device | 13. Partition (valve) |
| D. Relay instrument room | 6. Static contact box | 14. Secondary plug |
| 1. Leakage pressure device | 7. Current transformer | 15. Circuit breaker handcart operating mechanism |
| 1.1 Shell | 8. Grounding switch | 16. Circuit breaker handcart |
| 1.2 Secondary wiring slot | 9. Cable | 17. Extractable horizontal partition |
| 2. Branch bus | 10. Lightning arrester | 18. Earthing switch operating mechanism |
| | | 19. Bottom plate |



Overview

MNS low-voltage withdrawable switchgear (hereinafter referred to as switchgear) is composed of standardized, integrated series of modules, and the drawer has a reliable mechanical interlocking device, which makes the user safer and more reliable in use.

This switchgear is suitable for three-phase five-wire power supply system with AC 50(60) Hz, rated working voltage 400V, 660V, rated current 5000A and below, and can be used in power plants, substations, industrial and mining enterprises, building hotels, airports, terminals, radio and television and other communication centers are used as the control of power generation, transmission and distribution, power conversion and power consumption equipment, and reactive power compensation is performed on its main busbar through the capacitor compensation cabinet.

In line with national standards: GB7251.1 "Low-voltage switchgear" IEC60439 "Low-voltage switchgear and control equipment"

Model meaning

M N S - □ - □
① ② ③ ④ ⑤

①	Modular, modular
②	New
③	Electrical System
④	Main circuit scheme number
⑤	Auxiliary circuit scheme number

Conditions of Use

>The ambient air temperature is not higher than +40°C, not lower than -5°C, and the average temperature within 24h is not higher than +35°C;

>Atmospheric conditions: The air is clean, the relative humidity does not exceed 50% when the maximum temperature is +40°C, and a higher relative humidity is allowed at lower temperatures, such as 90% at +20°C, but temperature changes should be considered, there may be occasional condensation;

>The altitude does not exceed 2000m, which should be specified when ordering;

>The device is suitable for transportation and storage at the following temperatures: -25°C to +55°C, up to +70°C in a short time (not more than 24h), and the device should not be exposed to these extreme temperatures any irreversible damage and should function normally under normal conditions;

>If the above conditions of use cannot be met, it should be resolved through negotiation between the user and the manufacturer.

When the device is used in offshore oil drilling platforms and nuclear power plants, a separate technical agreement should be signed.

Technical parameter

Serial number	Project	GB7251.1 Low-voltage switchgear and control equipment (TTA) IEC60439 "Low-voltage switchgear and control equipment"	
1	Overvoltage category	IV, III	
2	Pollution level	3	
3	Rated working voltage (Ue) (V)	400/660	
4	Rated insulation voltage (Ui) (V)	660/1000	
5	Rated frequency(Hz)	50(60)	
6	Horizontal bus	Rated current	≤5000A
		Rated short-time withstand current (Icw) (kA)	50, 65, 80 (Is valid value)
		Rated peak withstand current (Ipk) (kA)	105, 140-176(0.1s max)
7	Vertical bus	Rated maximum working current	≤1000A
		Rated short-time withstand current	50kA
		Rated peak withstand current	105kA
8	Protection class	IP30/IP40 (Special instructions)	

Installation dimension drawing

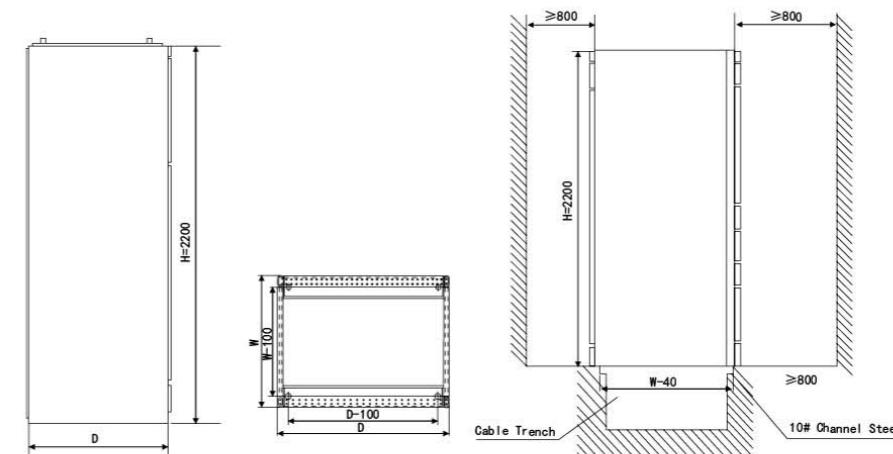

>Installation of MNS series switchgear is not vertical installation against the wall, behind it is the outlet cable trench of the cabinet. For easy maintenance, the distance from the rear to the wall is usually 800~1200mm, and the distance from the front is installed.

Download Google

The following technical information should be provided when ordering:

> Main circuit power distribution system diagram and floor plan, rated working voltage, rated working current, setting current of protection device and necessary technical parameters.

> Indicate the specifications of the incoming and outgoing cables.

>The model, specification and quantity of the main electrical components in the switchgear.

> If bus bridges or bus ducts are required between switch cabinets or incoming cabinets, specific requirements data such as span and height from the ground should be indicated.

>When the switchgear is used in special environmental conditions, it should be explained in detail when ordering.

>Surface color of switchgear and other specific requirements.

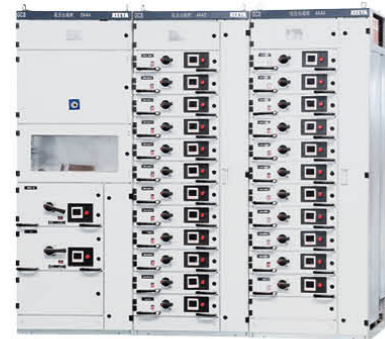

Overview

GCS devices are suitable for power distribution systems in power plants, petroleum, chemical, metallurgy, textile, high-rise buildings and other industries. In large power plants, petrochemical systems and other places with a high degree of automation and requiring computer interface, as a three-phase AC frequency of 50 (60) Hz, rated working voltage of 380V (400V, 660V), rated current of 4000A and below, Low-voltage complete sets of power distribution devices used in power distribution in power supply systems, centralized control of motors, and reactive power compensation.

Model meaning

G C S - □ - □
① ② ③ ④ ⑤

①	AC enclosed low-voltage switchgear
②	withdrawable
③	Electrical System
④	Main circuit scheme number
⑤	Auxiliary circuit scheme number

Conditions of Use

- >The ambient air temperature should not be higher than +40°C, not lower than -5°C, and the average temperature within 24 hours should not be +35°C.
- >Indoor use, the altitude of the place of use should not exceed 2000m, which should be specified when ordering;
- >The relative humidity of the surrounding air does not exceed 50% when the maximum temperature is +40°C, and a relatively large relative humidity is allowed at a lower temperature, such as 90% at +20°C. The effect of condensation.
- >When the device is installed, the inclination of the vertical plane should not exceed 50°, and the entire group of cabinets is relatively flat (in line with GBJ232-82 standard);
- >The device should be installed in a place without severe vibration and shock and not enough to prevent the electrical components from being corroded.



Technical parameter

Serial number	Project	Parameter	
1	Main circuit rated voltage (V)	AC 380 (400), (660)	
2	Auxiliary circuit rated voltage (V)	AC 220, 380 (400), DC 110, 220	
3	Rated frequency(Hz)	50(60)	
4	Rated insulation voltage (V)	660(1000)	
5	Rated current (A)	Horizontal bus	≤4000
		Vertical Busbar (MCC)	1000
6	Busbar rated short-time withstand current (kA, 1 s)	50,80	
7	Busbar rated peak withstand current (kA/0.1s)	105 ,176	
8	Power frequency testvoltage(V/1min)	The main circuit	2500
		Auxiliary circuit	1760
9	busbar	Three-phase five-wire system	A.B.C.PE.N
10	Protection class		IP30、IP40

Installation dimension drawing

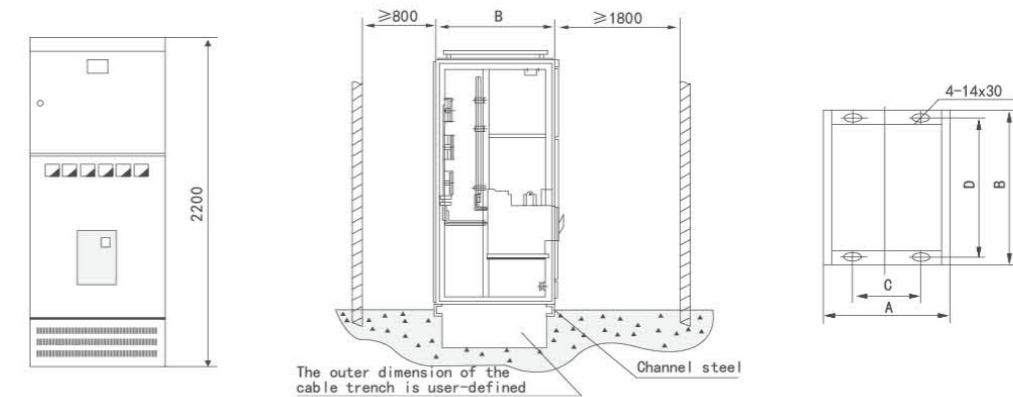

Universal cabinet code	A	B	C	D	Remark
GCS-TG1010-4	1000	1000	850	956	Contact Cabinet
GCS-TG0810-4	800	1000	650	956	Power receiving cabinet
GCS-TG0808-4	800	800	650	756	Power receiving cabinet
GCS-TG0608-4	600	800	450	756	Power receiving cabinet

Download Google

The following technical information should be provided when ordering:

- >The full model of the product includes the main circuit scheme number and the auxiliary circuit scheme number
- >Main circuit system combination sequence diagram
- >Auxiliary circuit electrical schematic
- >List of components in the cabinet
- >Setting parameters such as voltage, current and time in the circuit
- >Other special requirements that are inconsistent with the normal use of the product



Overview

GCK low-voltage withdrawable switchgear is composed of power distribution center (PC) cabinet and motor control center (MCC). In the power distribution system with current to 3150A, it is used for power conversion and distribution control of power distribution, motor control and lighting power distribution equipment.

Model meaning

G C K(L) - □ - □
① ② ③ ④ ⑤

①	AC enclosed low-voltage switchgear
②	withdrawable
③	Application code: K-control center, L-power
④	Design serial number: 1, 2, 3
⑤	Main circuit scheme number

Conditions of Use

- >The altitude should not exceed 2000m, which should be specified when ordering;
- >The ambient air temperature is not higher than +40°C, and the average temperature within 24 hours is not higher than +35°C, and the ambient air temperature is not lower than -50°C;
- >Atmospheric conditions: The air is clean, and the relative humidity does not exceed 50% when the temperature is +40°C, and a higher relative humidity is allowed when the temperature is low, for example: 90% at +20°C;
- > Places without fire, explosion hazard, serious pollution, chemical corrosion and severe vibration;
- >Inclination with vertical plane not more than 5°;
- >This product is suitable for transportation and storage at the following temperature: -25°C~+55°C, within a short period of time (not more than 24h), it does not exceed +70°C;
- >If the above conditions of use cannot be met, the user should propose it to our company when ordering, and resolve it through negotiation.



Technical parameter

Serial number	Project	Parameter	
1	Rated operating frequency (Hz)	50	
2	Rated working voltage (V)	380, 660	
3	Rated insulation voltage (V)	660	
4	Rated working current (A)	Horizontal bus	630-3150
		Vertical bus	600
5	Rated short-time withstand current	Horizontal bus	80kA (effective value)/1 second
		Vertical bus	50kA (effective value)/1 second
6	Rated peak withstand current	Horizontal bus	176kA/0.1s
		Vertical bus	110kA/0.1s
7	Main circuit connector (A)	200, 400	
8	Auxiliary circuit connector (A)	10	
9	Power frequency withstand voltage for 1 minute (V)	2500	
10	Protection class	IP40	
11	Operation method	local, remote, automatic	

Installation dimension drawing

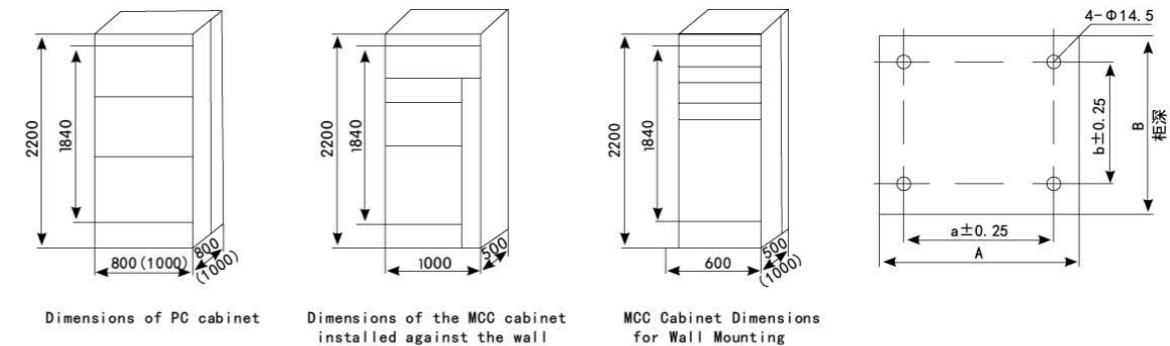

Cabinet width (A)	Cabinet depth (B)	Mounting hole distance (a)	Installation hole distance (b)
800	500	685	385
600	800	485	685
600	1000	485	885
800	800	685	685
800	1000	685	885
1000	800	885	685
1000	1000	885	885

Download Google

The following technical information should be provided when ordering:

- > Primary circuit scheme number, equipment model, capacity and single-line system diagram;
- > If the secondary circuit schematic diagram is not provided by the user, the manufacturer shall provide it according to the standard;
- > Arrangement diagram of switchgear and floor plan of power distribution room;
- > If the specifications of the main busbar are not provided as required, the manufacturer shall provide them according to the standard;
- > Surface color of switchgear (manufacturer's standard color: light bean color);
- > If the user has other requirements, they can negotiate with our factory.



Overview

GGD AC low-voltage switchgear is suitable for power distribution systems with AC 50Hz, rated working voltage 380V, and rated working current up to 3150A for power users such as power plants, substations, factories and mines. for control.

GGD AC low-voltage switchgear is a new type of AC low-voltage switchgear designed according to the requirements of the competent superiors of the Ministry of Energy and the majority of power users and design departments, and based on the principles of safety, economy, rationality and reliability. The product has the characteristics of high breaking capacity, good dynamic and thermal stability, flexible electrical scheme, convenient combination, series, strong practicability, novel structure, protection level, etc. It can be used as a replacement product for low-voltage switchgear.

GGD AC low-voltage switchgear complies with IEC 439 "Low-voltage switchgear and control equipment", GB 7251 "Low-voltage switchgear" and other standards.

Conditions of Use

- > The ambient air temperature should not be higher than +40°C, not lower than -5°C, and the average temperature within 24h should not be higher than +35°C;
- > For indoor installation and use, the altitude of the place of use should not exceed 2000m, which should be specified when ordering;
- > The relative humidity of the surrounding air does not exceed 50% when the maximum temperature is +40°C, and a larger relative temperature should be allowed at a lower temperature (eg 90% at +20°C) produce condensation effects;
- > When the equipment is installed, the inclination to the vertical plane should not exceed 5°;
- > The equipment should be installed in a place without severe vibration and shock and a place where the electrical components are not corroded;
- > When users have special requirements, they can negotiate with the manufacturer.



Technical parameter

Model	Rated voltage (V)	Rated current (A)		Rated short-circuit breaking current (kA)	Rated short-time withstand current (1s) (kA)	Rated peak withstand current (kA)
GGD1	380	A	1000	15	15	30
		B	600(630)			
		C	400			
GGD2	380	A	1500(1600)	30	30	60
		B	1000			
		C	600			
GGD3	38	A	3150	50	50	150
		B	2500			
		C	2000			

Installation dimension drawing

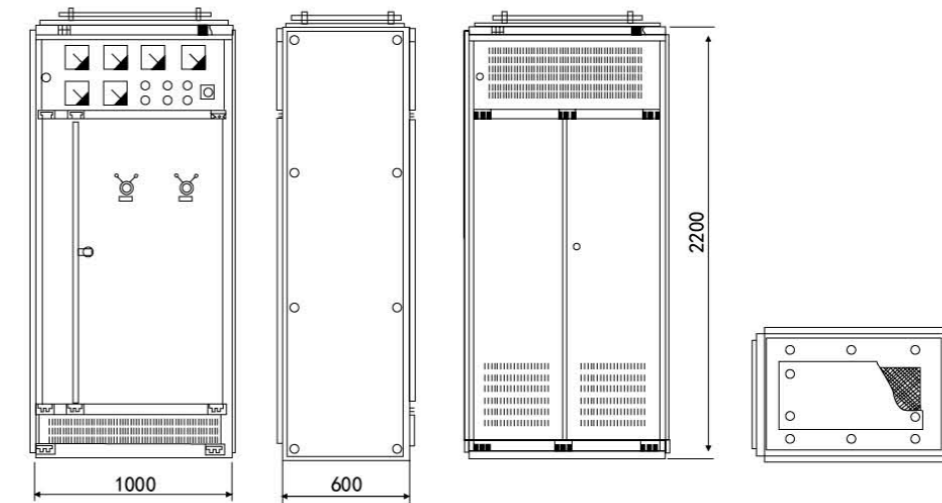

Download Google

When ordering, the user should provide:

- > Main circuit power distribution system diagram and floor plan, rated working voltage, rated working current, setting current of protection device and necessary technical parameters.
- > Indicate the specifications of the incoming and outgoing cables.
- >The model, specification and quantity of the main electrical components in the switchgear.
- > If bus bridges or bus ducts are required between switch cabinets or incoming cabinets, specific requirements data such as span and height from the ground should be indicated.
- >When the switchgear is used in special environmental conditions, it should be explained in detail when ordering.
- >Surface color of switchgear and other specific requirements.



Overview

Because the device can effectively improve the power factor of the electrical load, reduce the line loss, and improve the actual load capacity of the transformer, it has a significant energy-saving effect. At the same time, using a specific reactor in the system can also effectively prevent harmonic amplification and effectively absorb Most of the harmonic currents make the total harmonic voltage distortion rate limit and the harmonic current content limit of each order meet the national standard, so as to achieve the purpose of harmonic control. However, if an ordinary contactor is used to switch the capacitor bank, it will bring large inrush current, slow compensation time, high maintenance cost and short service life. Therefore, we recommend users to give priority to the following occasions. Consider using dynamic var compensation. For example, in the low-voltage power grids of industrial and mining enterprises' substations, production workshops and civil buildings, it is especially suitable for transmission and distribution systems with frequent load changes and unstable reactive power.

This product complies with: GB/T1 5576-2008 "Low-voltage complete sets of reactive power compensation equipment", IEC60439 "Low-voltage complete sets of switchgear and control equipment" and other standards.

Model meaning

GGJ - □ - □ / □ · □
① ② ③ ④ ⑤

①	Capacitor bank
②	Compensation method 1 is dynamic compensation, normal can be omitted
③	Compensation capacity kvar
④	Voltage class 230V 400V
⑤	Wiring method D: angle connection Y star connection

Conditions of Use

- > Ambient temperature: -5°C~+40°C;
- > Ambient relative humidity: no more than 90% (20°C);
- > Altitude: no more than 2000m, should be specified when ordering;
- > There is no danger of explosion in the surrounding medium, no gas enough to damage and corrode the metal, no conductive dust, the installation site is not easy to vibrate violently, and there is no erosion from rain and snow.

Technical overview

- > System voltage: below AC450V
- > Switching time: $t \leq 20\text{ms}$
- > Input inrush current: $< 25I_n$
- > Rated frequency: $50\text{Hz} \pm 5\%$
- > Sampling current: $0 \sim 5\text{A}$
- > Local power consumption: $\leq 15\text{W}$
- > Sensitivity: 100mA

Technical Features

- > Automatically compensate reactive power and improve power factor.
- > Improve equipment efficiency and save investment.
- > Reduce distribution line losses and transformer losses.
- > Change the voltage quality to improve the reliability of the power supply.

Features

Inductive loads in the power grid (generators, chokes, transformers, induction heaters and welding machines, etc.) will produce varying degrees of hysteresis, the so-called inductance. Inductive loads have the property that the direction of the current (eg, positive) can be maintained for a period of time when the voltage changes direction. Once this phase difference between current and voltage exists, reactive power is generated and fed back into the grid. In an AC grid (50/60Hz), the above process is repeated 50 or 60 times per second, so an obvious solution is to temporarily store and release this inductive power energy (reactive power) directly through capacitors, thereby reducing Reactive power exchange in the grid.

> Universal performance is strong. The compensation cabinet can be combined with various cabinets at home and abroad, such as MNS, GCK, GGD, etc.;

> The combination of capacitance compensation is diverse and flexible. It has Y-type compensation method, Δ -type compensation method, and $Y + \Delta$ 1 combined compensation method;

> Diversity of communication methods. With RS-232/485 communication interface, wireless data transmission module or GPRS module for long-distance communication;

> Controls are accurate and safe. Implement voltage zero-crossing trigger, no surge current zero-crossing cut-off when switching on, no high voltage generated when breaking;

> Long service life, under maintenance-free, the service life is more than 100,000 hours.

Installation dimension drawing

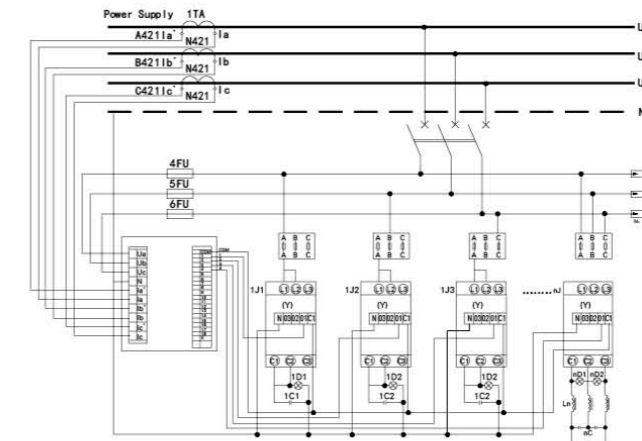

Download Google

- > Main circuit scheme diagram;
- > Compensation capacity and compensation method;
- > If it is inconsistent with the normal use conditions of the product, it must be explained in advance.



Overview

XL-21 power cabinet is widely used in power plants and industrial and mining enterprises for power or lighting distribution in power distribution systems such as three-phase three-wire, three-phase four-wire, three-phase five-wire and other power distribution systems below 500V. It is installed against the wall inside, operated in front of the screen, and overhauled in front of the screen; the box body is a fully enclosed structure, assembled from C profiles or 8MF profiles. A new type of rotary load isolation switch is used in the box, which can be operated with load. The front door is equipped with voltage and current indicating instruments, as well as main components such as signal lights, buttons, and transfer switches. The distribution box adopts new components, with compact structure, beautiful appearance, convenient maintenance, and a variety of wiring schemes for users to choose.

Model meaning

X L (F) - 21 - □
① ② ③ ④ ⑤

①	Box
②	Power
③	Dustproof
④	Design serial number: 1, 2, 3
⑤	Main circuit scheme number

Conditions of Use

>Ambient temperature: -5°C~+40°C, and the average temperature within 24h does not exceed +35°C;

>Altitude: no more than 2000m;

>Relative humidity: no more than 50% when the ambient air temperature is +40°C; higher relative humidity (eg: 90% at +20°C) at a lower temperature, taking into account the change in temperature allows a moderate thecondensation;

>When the equipment is installed, the inclination from the vertical plane should not exceed 5°;

>The equipment should be installed in a place without severe vibration, shock and corrosion.

Note: If the above conditions are exceeded, you can negotiate with our company.



Technical parameter

Serial number	Project	Unit	Data
1	Main circuit rated voltage	V	AC:380
2	Auxiliary circuit rated voltage	V	AC:220,380
3	Rated frequency	Hz	50
4	Rated insulation voltage	V	660
5	Rated current	A	≤800A

Installation dimension drawing

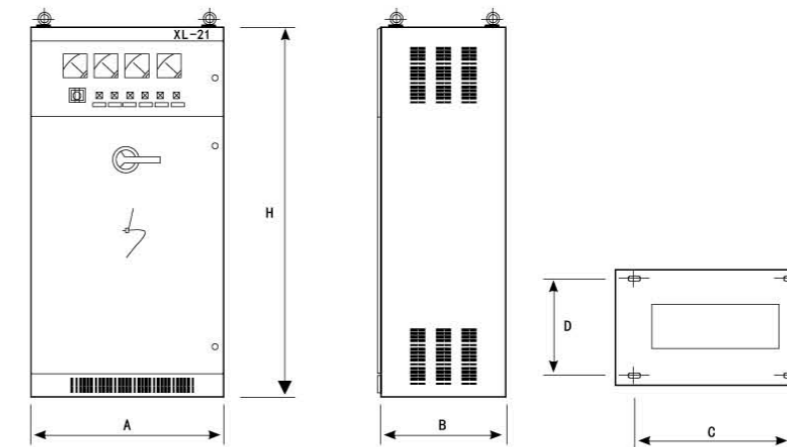

A	B	C	D	H
800(600)Optional	500(400)Optional	650(450)	450(350)	1800(1600)Optional

Download Google

The following technical information should be provided when ordering:

>All models of the product (including the main circuit scheme number and the auxiliary circuit scheme number);

>Main circuit system diagram, cabinet layout diagram;

>Auxiliary circuit electrical schematic diagram;

> List of components in the cabinet (main busbar specifications);

>Cabinet color, (if there is no requirement, it will be supplied in light camel gray) box size;

>Other special requirements that are inconsistent with the normal use conditions of the product;

>If the main busbar specification is not provided as required, the manufacturer shall provide it according to the standard.

QYV-12D/630-25

SF6 gas-filled cabinet circuit breaker (with isolation belt grounding)



Overview

This circuit breaker is mainly used for inflatable cabinets. The product adopts the plywood structure type. It has the advantages of simple and convenient installation, reliable breaking performance, long service life and maintenance-free. It is an ideal substitute for vacuum circuit breakers for inflatable cabinets.

The product performance meets the requirements of GB1984-2014 "AC High Voltage Circuit Breaker" E2-M2-C2 class circuit breaker.

Conditions of Use

>The altitude should not exceed 2000m, and the degree of shattering should not exceed 8 degrees.

>The ambient air temperature is lower than +50 degrees Celsius, not lower than -40 degrees Celsius. The daily average of relative temperature is not more than 95%, and the monthly average is not more than 90%.

>It is not suitable for installation sites with frequent violent vibrations, water vapor, gas, chemical corrosive deposits, salt spray, dust and dirt, fire and explosion hazards that obviously affect the performance of the mechanism.

>The rated SF6 gas pressure is 0.04MPa, and the SF6 gas meets the requirements of GB/T 12022-2014 "Industrial Sulfur Hexafluoride".

Technical parameter

Serial number	Content	Unit	Technical parameter
1	Rated voltage	kV	12
2	Rated frequency	Hz	50
3	Rated current	A	630
4	Rated short-time withstand current	kA	20/25
5	Rated peak withstand current	kA	50
6	Rated short circuit duration	s	4
7	Rated short-circuit making current	kA	50
8	theoretical operation	Frequency	10000
9	Main circuit resistance	$\mu\Omega$	≤ 60
10	1min power frequency withstand voltage	kV	38(in the air)

QYV-12D/630-25

SF6 gas-filled cabinet circuit breaker (with isolation belt grounding)

Installation dimension drawing

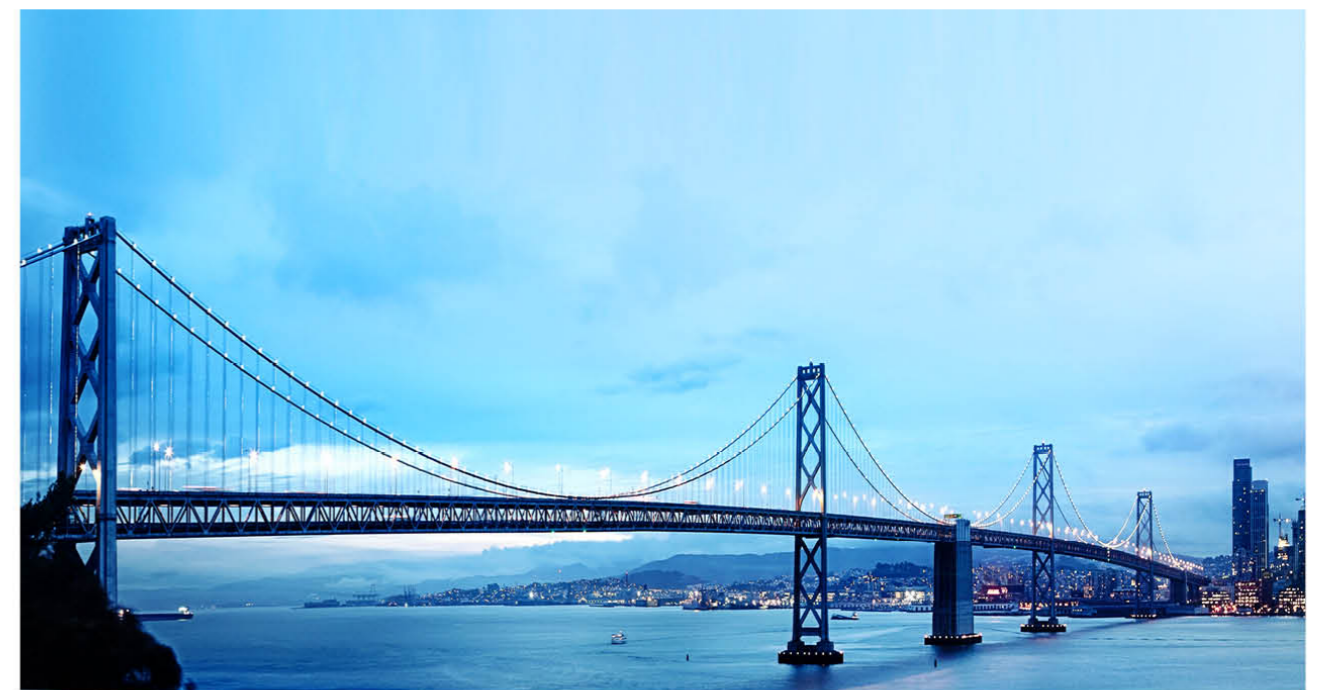
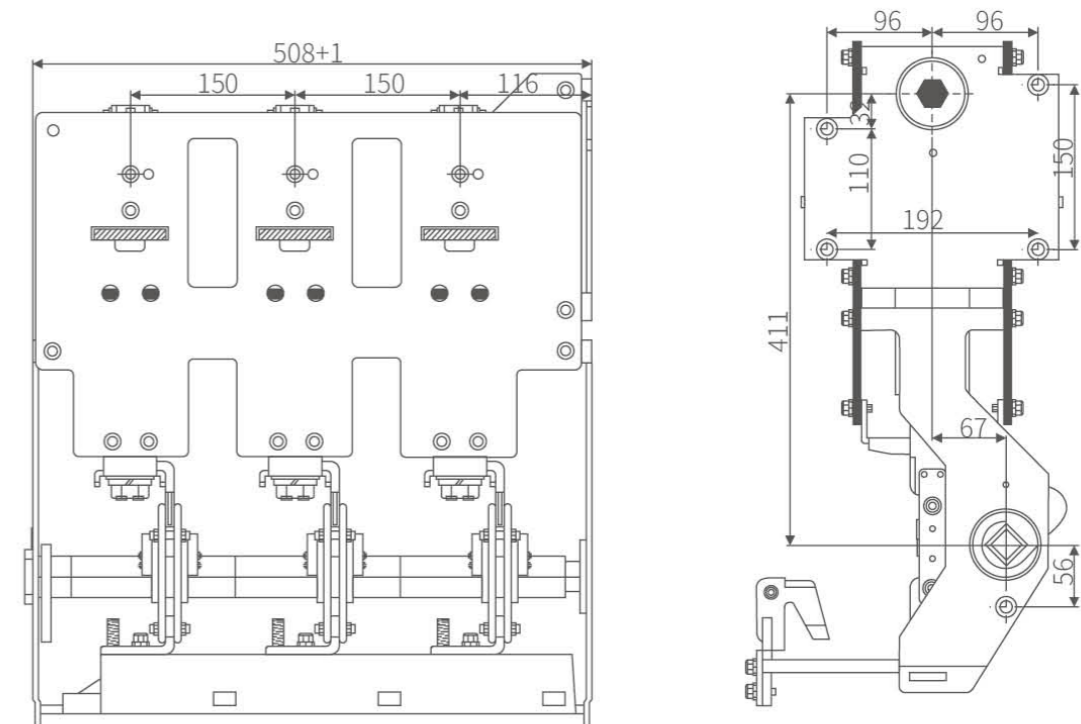

QYV-12D/630-25

SF6 gas-filled cabinet circuit breaker (without isolation and without grounding)



Overview

This circuit breaker is mainly used for inflatable cabinets. The product adopts the plywood structure type. It has the advantages of simple and convenient installation, reliable breaking performance, long service life and maintenance-free. It is an ideal substitute for vacuum circuit breakers for inflatable cabinets.

The product performance meets the requirements of GB1984-2014 "AC High Voltage Circuit Breaker" E2-M2-C2 class circuit breaker.

Conditions of Use

>The altitude should not exceed 2000m, and the degree of shattering should not exceed 8 degrees.

>The ambient air temperature is lower than +50 degrees Celsius, not lower than -40 degrees Celsius. The daily average of relative temperature is not more than 95%, and the monthly average is not more than 90%.

>It is not suitable for installation sites with frequent violent vibrations, water vapor, gas, chemical corrosive deposits, salt spray, dust and dirt, fire and explosion hazards that obviously affect the performance of the mechanism.

>The rated SF6 gas pressure is 0.04MPa, and the SF6 gas meets the requirements of GB/T 12022-2014 "Industrial Sulfur Hexafluoride".

Technical parameter

Serial number	Content	Unit	Technical parameter
1	Rated voltage	kV	12
2	Rated frequency	Hz	50
3	Rated current	A	630
4	Rated short-time withstand current	kA	20/25
5	Rated peak withstand current	kA	50
6	Rated short circuit duration	s	4
7	Rated short-circuit making current	kA	50
8	theoretical operation	Frequency	10000
9	Main circuit resistance	$\mu\Omega$	≤ 60
10	1min power frequency withstand voltage	kV	38(in the air)

QYV-12D/630-25

SF6 gas-filled cabinet circuit breaker (without isolation and without grounding)

Installation dimension drawing

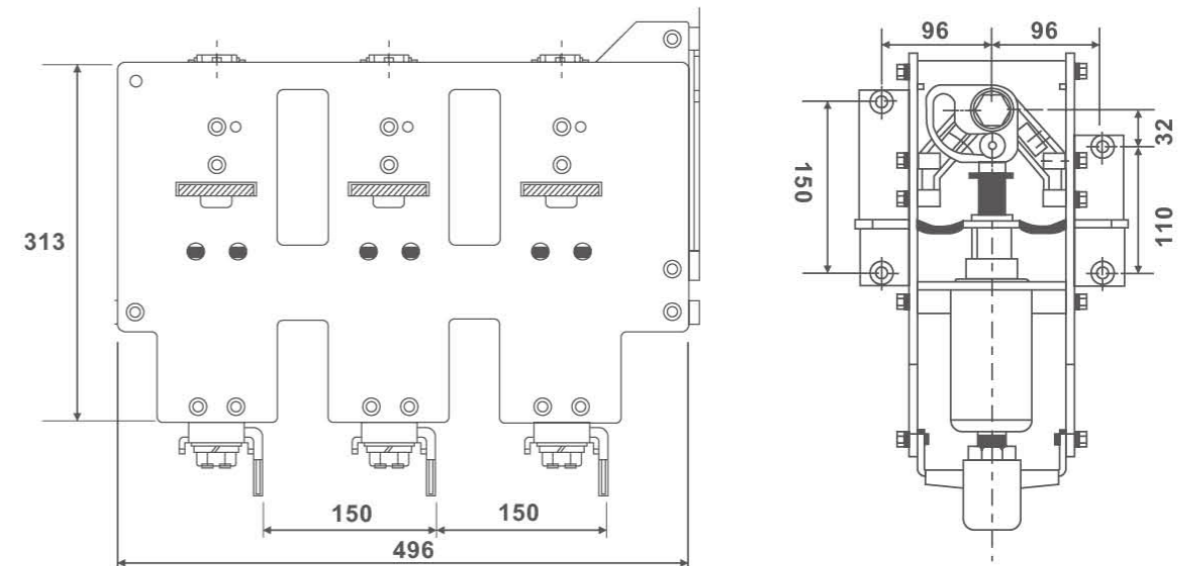

QYV-12D/630-31.5

SF6 inflatable cabinet load switch

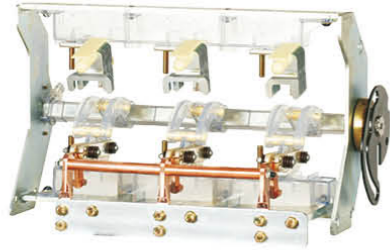

Overview

The load switch is a SF6 gas-filled cabinet load switch, the product is a rotary blade structure, and uses an arc extinguishing grid to extinguish the arc, with reliable performance, good insulation performance and breaking performance.

The product performance meets the requirements of GB1985-2004 "High-voltage AC isolating switch and grounding switch" E3-M2 isolating switch.

Conditions of Use

>The altitude should not exceed 2000m, and the degree of shattering should not exceed 8 degrees.

>The ambient air temperature is lower than +50 degrees Celsius, not lower than -40 degrees Celsius. The daily average of relative temperature is not more than 95%, and the monthly average is not more than 90%.

>It is not suitable for installation sites with frequent violent vibrations, water vapor, gas, chemical corrosive deposits, salt spray, dust and dirt, fire and explosion hazards that obviously affect the performance of the mechanism.

>The rated SF6 gas pressure is 0.04MPa, and the SF6 gas meets the requirements of GB/T 12022-2014 "Industrial Sulfur Hexafluoride".

Technical parameter

Serial number	Content	Unit	Technical parameter
1	Rated voltage	kV	12
2	Rated frequency	Hz	50
3	Rated current	A	630
4	Rated short-time withstand current	kA	20/25
5	Rated peak withstand current	kA	50
6	Rated short circuit duration	s	4
7	Rated short-circuit making current	kA	50
8	theoretical operation	Frequency	10000
9	Main circuit resistance	$\mu\Omega$	≤ 35

QYV-12D/630-31.5

SF6 inflatable cabinet load switch

Installation dimension drawing

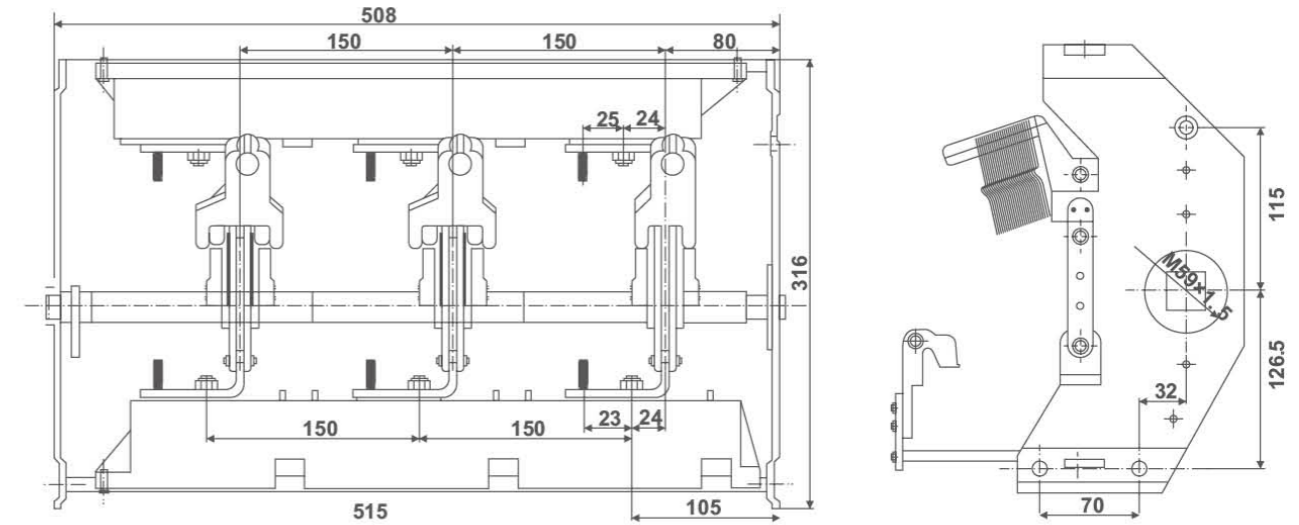



Overview

The solid insulation switch is the core of the solid insulation ring network cabinet. It is an integrated design of vacuum circuit breaker or load switch, isolating switch, and grounding switch. It has a compact structure and adopts a front and rear arrangement, one time part. The unnecessary transmission links in the middle are reduced, labor and parts are saved, and the transmission efficiency is high. The primary part adopts the APG automatic gel process, and the vacuum interrupter, isolation and grounding switch of the primary part are completely sealed in a special epoxy resin. As a solid-sealed pole unit, its insulation and electrical properties are superior. The solid insulation switch can be assembled as a module with the switch cabinet to form different functional units; the operating mechanism of the switch and the operating mechanism of the isolating switch are both modular mechanisms, and the elastic operating mechanism of the isolating switch and the main switch has achieved interlocking, and There are few mechanism parts, unnecessary transmission links are reduced, and the reliability is high, and the isolation switch can be operated electrically according to the needs of users.

- > Integrated pole unit, high creepage distance, excellent electric field performance;
- > Adopt vacuum interrupter, knife gate isolation and grounding switch;
- > The switch body has high protection level and has anti-condensation function;
- > The main busbar outlet and cable outlet adopt standard European connectors, which are easy to combine cabinets and are safe and reliable;
- > Special epoxy resin insulation material:
 - a. High mechanical strength;
 - b. Good cracking resistance, heat shrinkage, thermal conductivity and aging resistance;
 - c. High glass transition temperature greater than 110°C, so that the insulating ability of epoxy resin does not decrease under high temperature operating environment;
- > The unique design of the fuse barrel structure, horizontal placement and fuse front method, easy to replace the fuse pipe, simple and reliable firing pin mechanism, can also effectively prevent water vapor from entering the barrel, improving the safety of long-term operation;
- > The interface of the operating mechanism is simple and clear, easy to operate, the mechanical interlock position of the switch is simple and reliable, which can effectively prevent misoperation, and the isolation fracture can be seen with LED lights, which is highly safe;
- > The isolating switch can realize electric operation according to the needs of users, and can truly realize the automation of distribution network;
- > Easy maintenance, parts replacement and circuit inspection can be performed by opening the panel.

Conditions of Use

- > Altitude: $\leq 4000\text{m}$;
- > Ambient temperature: -45°C ~ $+70^{\circ}\text{C}$;
- > Relative humidity: daily average relative humidity $\leq 95\%$, monthly average relative humidity $\leq 90\%$;
- > Installation environment: the surrounding air is free of explosive and corrosive gases, the installation site is free from severe vibration and shock, and the pollution level does not exceed level III in GB/T5582;
- > Seismic strength: ≤ 9 degrees;
- > Please negotiate with our company for special environment use;

Application field

- > Low temperature and cold area: no SF6 gas application, no need to consider the low temperature operation of SF6 gas, and it can operate normally at -45°C .
- > Plateau area: It is not necessary to consider the influence of plateau atmospheric pressure on insulation performance.
- > Strong sandstorm areas: The safety protection level of the solid insulation ring network cabinet is IP67, and the control circuit room adopts special treatment to ensure long-term operation in strong sandstorm areas.
- > Coastal wet areas: epoxy resin sealing, anti-moisture, anti-salt spray corrosion, to ensure long-term use in coastal areas.
- > Areas with high environmental protection requirements: The impact of SF6 gas on atmospheric warming has been highly regarded, and the solid ring main unit has cancelled SF6 gas, which does not cause any pollution and harm to the environment and people.
- > In the smart grid: because the main switch and the isolation switch can be powered, the intelligent controller developed by our company can be selected, which can perform remote control, telemetry and remote communication on the switchgear and substation site, which can not only carry out decentralized control, but also facilitate Centralized control.

Installation dimension drawing

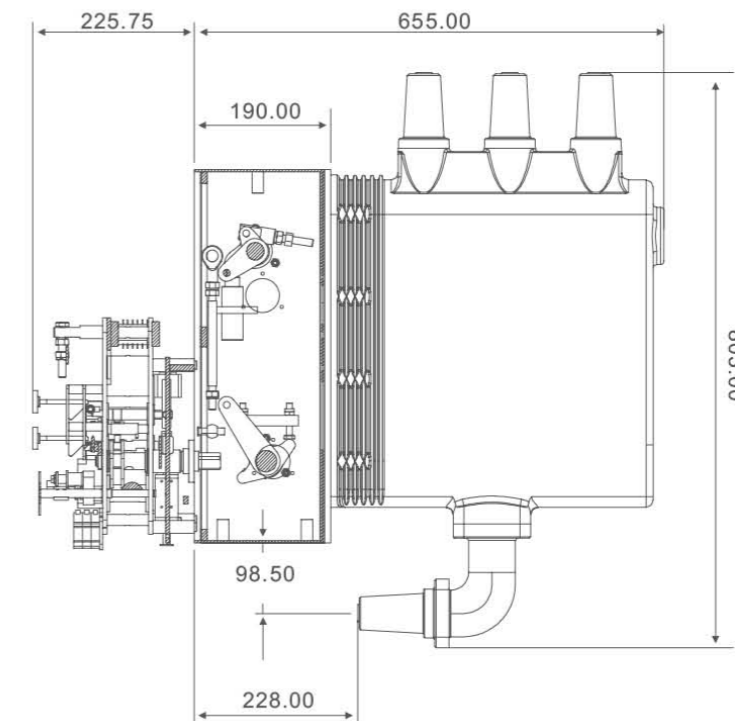

FLN36-12D

AC High Voltage Sulfur Hexafluoride Load Switch



Overview

FLN36-12D, FLRN36-12D AC high voltage sulfur hexafluoride load switch, load switch-fuse combination electrical appliance and cable head type load switch are our company's digestion and absorption of foreign advanced technology, combined with my country's operating requirements, self-designed and developed become. The product has undergone a comprehensive type test, and its performance meets the requirements of GB3804 "3~63kV AC High Voltage Load Switch", GB16926 "High Voltage Load Switch-Fuse Combination Electric Appliance", IEC60265, IEC60420 standards. The product has a three-position arc extinguishing chamber of "combining-dividing-grounding", with reliable interlocking, high fracture insulation strength, large creepage design, and the outlet end is protected by a voltage equalizing protective cover. It is equipped with a cable head type load switch, the outlet end is equipped with a touchable cable front connector, and the inlet and outlet lines are installed with high-voltage cables, which are used in the cable branch (connection) box.

Model meaning

FL N 36 - 12 D / T 630 - 20

① ② ③ ④ ⑤ ⑥ ⑦ ⑧

①	Sulfur Hexafluoride Load Switch
②	Indoor
③	Design Number
④	Rated voltage
⑤	with earthing switch
⑥	Spring operating mechanism
⑦	Rated current
⑧	Rated short-time withstand current

Conditions of Use

- > Normal use conditions
- > Ambient temperature -25°C~+40°C
- > Altitude: no more than 2000m
- > Humidity conditions: the average relative humidity does not exceed 95%, the average monthly relative humidity does not exceed 90%, the average daily water vapor pressure does not exceed 2.2kPa, and the average monthly water vapor pressure Not more than 1.8kPa
- > The surrounding air is not significantly polluted by dust, smoke, corrosive and/or flammable gases, steam or salt mist
- > Vibration or ground motion from outside of switchgear and control equipment is negligible
- > The amplitude of electromagnetic interference induced in the secondary system shall not exceed 1.6kV.

> Special Conditions of Use

According to the national standard GB/T11022-1999, "Common technical requirements for high-voltage switchgear and control equipment standards", the circuit breaker should operate under normal conditions of use. If the working conditions used by the user are different from the normal use conditions, such as: the installation site is at an altitude of more than 2000m, the ambient air temperature exceeds the limit specified in the normal use conditions, or the high humidity is prone to condensation, it should be negotiated with the manufacturer, and reached consensus.

FLN36-12D

AC High Voltage Sulfur Hexafluoride Load Switch

Technical parameter

Serial number	name	Unit	Data		
			(NX)FLN36-12D	(NX)FLRN36-12D	
1	Rated voltage	kV	12	12	
2	Rated frequency	Hz	50	50	
6	Rated current	A	630	125	
4	Load switch rated short-time withstand current / rated short-circuit duration	kA/s	20/3	-	
	Earthing switch rated short-time withstand current/rated short-circuit duration	kA/s	20/2	-	
5	Rated peak withstand current and rated short-circuit making current	kA	50	125(预期)	
6	Rated breaking current	Active load breaking current	A	630	-
		Closed-loop breaking current	A	630	-
		5% of rated active load breaking current	A	31.5	-
		Disconnect cable charging current	A	10	-
		Breaking no-load transformer capacity	kVA	1250	1250
		Break transfer current	A	-	1700
7	rated absolute edge level	1min power frequency withstand voltage phase-to-phase, to ground/fracture	kV	42/48	42/48
		Lightning impulse withstand voltage phase-to-phase, to ground/fracture	kV	75/85	75/85
8	Main circuit, ground circuit mechanical life		3000/2000	2000/2000	
9	SF6 rated air pressure (gauge pressure at 20° C)	MPa	0.04~0.05	0.04~0.05	

Installation dimension drawing

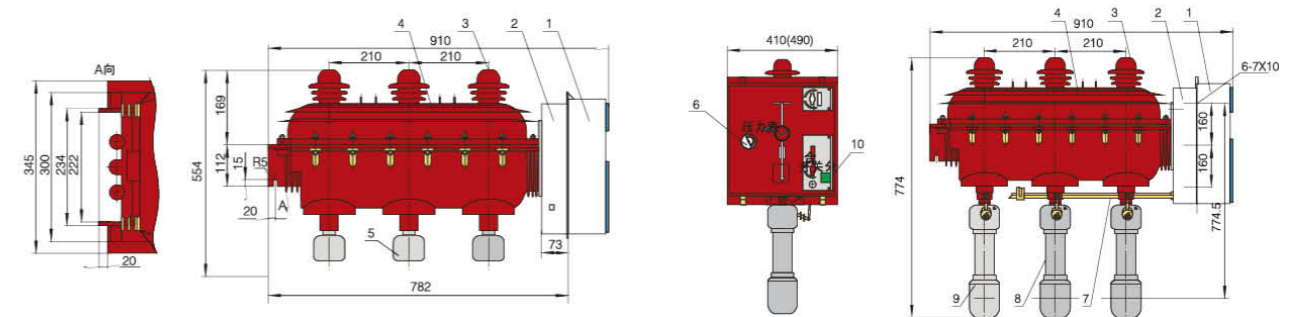

Outline dimension drawing of load switch

Outline dimension drawing of combined electrical appliance

1. Mechanism cover
2. Mechanism
3. Upper terminal shield
4. Load switch body
5. Lower terminal shielding or fuse upper contact holder

6. SF6 pressure gauge
7. Impact tripping system
8. Fuse
9. Lower contact seat of fuse
10. Opening button

QYV(VS1)-12

Fixed indoor high voltage vacuum circuit breaker



Overview

QYV(VS1)-12 fixed indoor high-voltage vacuum circuit breaker is an indoor switchgear for three-phase AC 50Hz rated voltage 12kV power system, as a protection and control unit for power grid equipment and power equipment in industrial and mining enterprises. It is suitable for places that require frequent operation at rated working current, or break short-circuit current for many times.

The circuit breaker adopts the integrated design of the operating mechanism and the circuit breaker body, which can be used as a fixed installation unit or equipped with a special propulsion mechanism to form a handcart unit.

Model meaning

QY VS 1- 12/ □ - □ - □
① ② ③ ④ ⑤ ⑥ ⑦

①	Enterprise code
②	Vacuum circuit breaker
③	Design Number
④	Rated voltage (KV)
⑤	Rated current (A)
⑥	Rated short-circuit breaking current (KA)
⑦	Stationary

Conditions of Use

- > Ambient air temperature: upper limit +40°C. Lower limit -15°C;
- > Altitude: ≤1000m (if the altitude needs to be increased, the rated insulation level should be increased accordingly);
- > Amplitude: The seismic intensity does not exceed 8 degrees;
- > The daily average relative humidity of the air is not more than 95%, and the monthly average is not more than 90%
- > Places without fire, explosion hazard, serious pollution, chemical corrosion and severe vibration.



QYV(VS1)-12

Fixed indoor high voltage vacuum circuit breaker

Technical parameter

Serial number	Project	Unit	data					
1	Rated voltage	kV	12					
2	Rated frequency	Hz	50					
3	Rated insulation level	kV	Ground/Alternate 42/48					
			Lightning impulse withstand voltage (peak)					
4	Rated short-circuit breaking current	kA	20	25	31.5	40		
			630	630	1250	1600	1250	1600
5	Rated current	A	1250	1250	2000	2500	2000	2500
			20	25	31.5	40		
6	Rated short-time withstand current (RMS)	kA	50	63	80	100		
			50	63	80	100		
7	Rated peak withstand current (peak)	kA	50	63	80	100		
8	Rated short-circuit making current (peak value)	kA	50	63	80	100		
9	Rated short-circuit current duration	S	4					
10	Mechanical life	Second-rate	20000					
11	Secondary circuit power frequency withstand voltage (1min)	V	2000					
12	Nominal Operation Sequence		o-t-co-t1-co					

Note: 20kA, 25kA, 31.5kA t = 0.3s t1 = 180s; 40kA t = 180s t1 = 180s

Installation dimension drawing

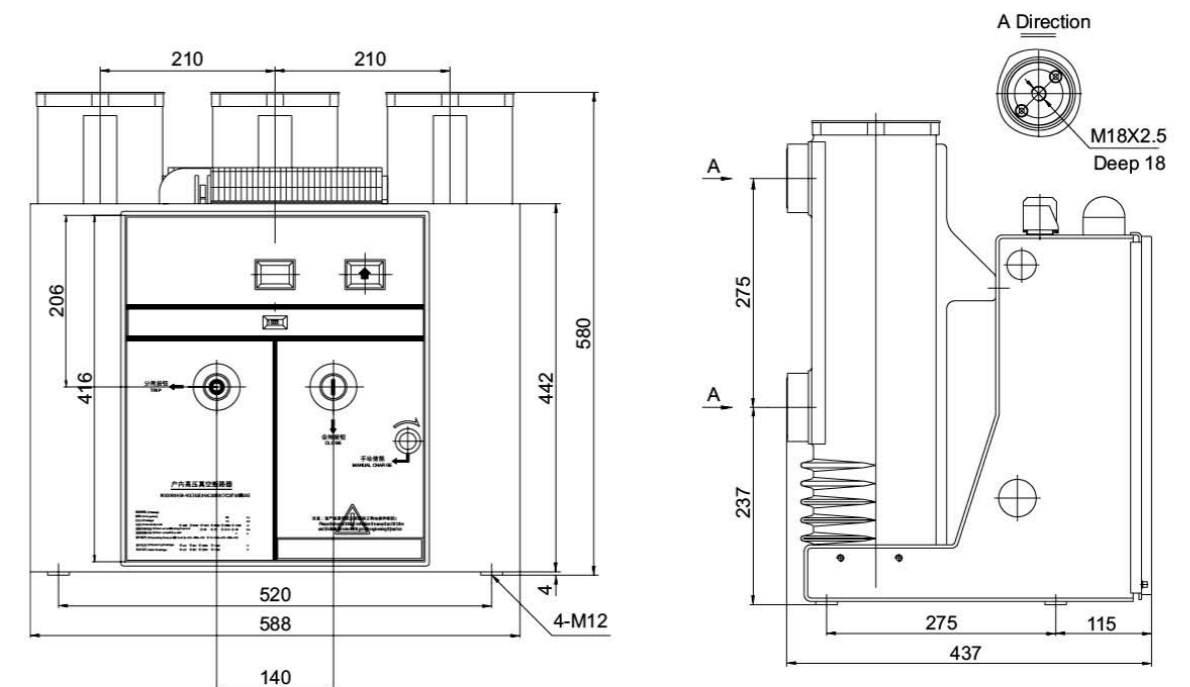

ZW32-12F

Outdoor AC high voltage demarcation vacuum circuit breaker



Overview

ZW32-12 outdoor AC high voltage vacuum circuit breaker (hereinafter referred to as circuit breaker) is an outdoor power distribution equipment with a rated voltage of 12kV and a three-phase AC 50Hz. It is mainly used for breaking and closing the load current, overload current and short-circuit current in the power system. It is suitable for protection and control in substations and power distribution systems of industrial and mining enterprises, and places where rural power grids operate frequently. The circuit breaker has the characteristics of small size, light weight, anti-condensation, maintenance-free, etc., and can adapt to harsh climatic conditions and dirty environments.

Model meaning

X L (F) - 21 - □
① ② ③ ④ ⑤

①	Box
②	Power
③	Dustproof
④	Design serial number: 1, 2, 3
⑤	Main circuit scheme number

Conditions of Use

- > Ambient temperature: -40°C~+40°C;
- > The altitude does not exceed 2000m, and the altitude above 2000 is negotiated with the user;
- > Wind pressure does not exceed 700Pa (equivalent to wind speed 34m/s);
- > The daily average value of relative temperature is not more than 95%, and the monthly average value is not more than 90%;
- > Air pollution class III;
- > The surrounding air should not be obviously polluted by corrosive gas or flammable gas;
- > No frequent violent vibration.

Technical parameter

Serial number	Name	Unit	Parameter
1	Rated voltage	kV	12
2	Rated frequency	Hz	50
3	Rated current	A	630/1250
4	Rated short-circuit breaking current	kA	20/25/31.5
5	Rated peak withstand current (peak)	KA	50
6	Rated short-time withstand current	kA	20
7	Rated short-circuit making current (peak value)	kA	50
8	Mechanical life	Second-rate	10000
9	Rated short-circuit breaking current breaking times	Second-rate	≥ 30
10	Power frequency withstand voltage (1min): (wet) (dry) phase-to-phase, to ground/fracture	kV	42/4
11	Lightning impulse withstand voltage (peak value) phase-to-phase, to ground/fracture	kV	875/85
12	Secondary circuit Imin power frequency withstand voltage	kV	2

ZW20-12F

Intelligent vacuum circuit breaker (watchdog)



Overview

ZW20-12F intelligent vacuum circuit breaker (with watchdog) is an outdoor high-voltage switchgear with a rated voltage of 12kV and a three-phase AC 50Hz. It is mainly used for breaking and closing the load current, overload current and short-circuit current of the power system. It is suitable for protection and control of substations, industrial and mining enterprises and urban and rural distribution networks, especially for places with frequent operations and automatic distribution networks of urban networks. This product is matched with the controller, which can meet the requirements of the distribution automation system, and can reliably and effectively complete the traditional recloser function. It adopts a mature box-type sealing structure, filled with SF6 gas, and has good sealing performance, so that it is not affected by the external environment, and is a maintenance-free product. Its spring operating mechanism adopts direct-acting chain main drive and multi-stage tripping system, with high action reliability, which is the best product for pole-mounted circuit breakers.



Model meaning

Z W 20 - 12 F / T □ - □
① ② ③ ④ ⑤ ⑥ ⑦ ⑧

①	Vacuum
②	Outdoor
③	Design Number
④	Rated voltage (kV)
⑤	Smart controller
⑥	Spring operating mechanism
⑦	Rated current
⑧	Rated short-circuit breaking current

Technical parameter

Name	Unit	Parameter
Rated voltage	KV	12
Rated frequency	Hz	50
Rated current	A	630
Rated short-circuit breaking current	KA	20
Rated making current peak	KA	50
Rated dynamic stable current peak	KA	50
4s thermal stable current	KA	20
Nominal Operation Sequence		Points-0.3s-Combined points-180s-Combined points
Rated energy storage motor voltage	V	AC220
Maximum/minimum energy storage motor voltage	V	AC242/87
Rated closing operating voltage	V	AC220
Maximum/minimum closing operating voltage	V	AC264/43
Rated opening operating voltage	V	AC220
Maximum/minimum opening operating voltage	V	AC264/43
Closing in different periods	ms	≤ 2
Different period of opening	ms	≤ 2
SF6 gas rated pressure (gauge pressure)	Mpa	0.01
Rated short-circuit current breaking times	Second-rate	≥ 30
Mechanical life	Second-rate	10000

S11-M

Fully sealed oil-immersed power transformer



Overview

S11-M fully sealed oil-immersed power transformer is suitable for power systems with AC 50Hz, rated working voltage of 10kV and below, as distribution transformers in petroleum, metallurgy, chemical, textile, light industry and other enterprises and places with large dust.

The product conforms to the standard: GB1094.1-5

Model meaning

S 11 M - □ / 10
① ② ③ ④ ⑤

①	three phase
②	Design Number
③	fully sealed
④	Rated capacity (kVA)
⑤	High voltage side voltage level (kV)

Conditions of Use

- > Installation height: no more than 1000m above sea level;
- > Ambient temperature: -40°C~+40°C.

Technical parameter

Rated Capacity (kVA)	Voltage combination			Tie group label	Load loss (W)	load loss (W)	No-load current (%)	Short circuit impedance (%)	Weight (kg)	
	High voltage (kV)	High voltage tap range	Low voltage (kV)						Oil weight	Gross weight
30	6 6.3 6.6 10 10.5 11	±5% ±2X2.5%	0.4	Yyn0 Dyn11	100	630/600	2.1	4	75	295
50					130	910/870	1.1		88	395
63					150	1090/1040	1		95	420
80					180	1310/1250	1		103	480
100					200	1580/1500	0.9		115	540
125					240	1890/1800	0.9		130	645
160					280	2310/2200	0.8		145	740
200					340	2730/2600	0.8		175	885
250					400	3200/3050	0.7		195	1010
315					480	3830/3650	0.7		230	1205
400	570	4520/4300	0.6	255	1375					

S11-M

Fully sealed oil-immersed power transformer

Rated Capacity (kVA)	Voltage combination			Tie group label	Load loss (W)	load loss (W)	No-load current (%)	Short circuit impedance (%)	Weight (kg)	
	High voltage (kV)	High voltage tap range	Low voltage (kV)						Oil weight	Gross weight
500	6 6.3 6.6 10 10.5 11	±5% ±2X2.5%	0.4	Yyn0 Dyn11	680	5410/5150	0.6	4.5	285	1620
630					810	6200	0.6		350	1960
800					980	7500	0.5		405	2310
1000					1150	10300	0.5		490	1690
1250					1360	12000	0.5		550	3315
1600					1640	14500	0.4		625	3795

Note: The load loss values above the slashes in the table apply to Dyn11 or Yzn11 connection groups, and the load loss values below the slashes apply to Yyn0 connections.

Installation dimension drawing

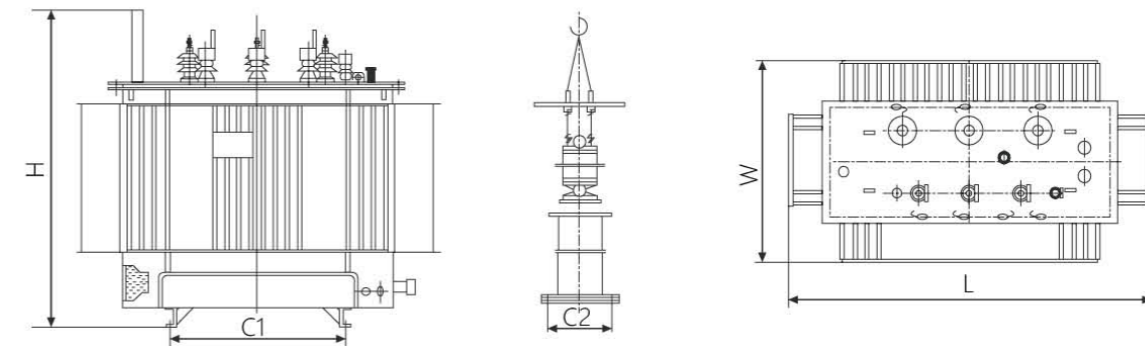

Rated Capacity(kVA)	Outline and installation dimensions (mm)				
	L	w	H	C1	C2
30	750	643	974	400	400
50	795	493	1013	400	400
63	800	665	1050	400	400
80	840	680	1075	400	400
100	775	690	1100	550	550
125	1260	900	1045	550	550
160	1090	720	1140	550	550
200	1180	780	1155	550	550
250	1175	750	1180	550	550
315	1315	890	1240	660	660
400	1330	910	1280	660	660
500	1390	930	1340	660	660
630	1545	1030	1410	820	820
800	1570	1020	1535	820	820
1000	1800	1250	1430	820	820
1250	1910	1130	1650	820	820
1600	2010	1220	1740	820	820
2000	2120	1280	1780	820	820

SC(B)10

Epoxy resin cast dry type transformer



Overview

This product has a wide range of application fields, especially suitable for use in places with high fire protection requirements, such as mines, oil fields, subways, power plants, schools, hospitals, commercial centers, high-rise buildings and all indoor configuration systems.

Products meet the standards: GB1094.1-5, GB1094.11.

Model meaning

S C (B) - 10 - □ / 10
① ② ③ ④ ⑤ ⑥

①	Three phase
②	Formed solid casting
③	Low Voltage Foil Coil
④	Design Number
⑤	Rated capacity (kVA)
⑥	High voltage side voltage level (kV)

Conditions of Use

- >Installation height: the altitude does not exceed 1000m;
- > The waveform of the power supply voltage: similar to a sine wave;
- >Symmetry of the multi-phase power supply voltage: the power supply voltage connected to the multi-phase transformer should be approximately symmetrical;
- >Minimum temperature -30°C (for indoor transformers);
- >The highest daily average temperature +30°C;
- >The highest annual average temperature is +20°C.

Technical parameter

Rated Capacity (kVA)	Voltage combination			link group label	Loss (120° kW)			Short circuit impedance (%)	Weight (kg)	
	High voltage (kV)	High voltage tap range	Low voltage (kV)		load	no load	No-load current(%)		Real weight	Heavy with shell
30	6 6.3 6.6 10 10.5 11	±5% ±2X2.5%	0.4	Yyn0 Dyn11	0.71	0.19	1.6	4	220	250
50					1	0.27	1.4		360	410
80					1.38	0.37	1.2		450	490
100					1.57	0.4	1.1		540	580
125					1.85	0.47	1.0		630	670
160					2.13	0.54	1.0		745	795
200					2.52	0.62	0.9		850	910
250					2.75	0.72	0.8		1010	1065
315					3.47	0.88	0.8		1235	1295
400					3.99	0.98	0.7		1370	1430
500	4.88	1.16	0.7	1565	1625					

SC(B)10

Epoxy resin cast dry type transformer

Rated Capacity (kVA)	Voltage combination			link group label	Loss (120° kW)		No-load current(%)	Short circuit impedance (%)	Weight (kg)		
	High voltage (kV)	High voltage tap range	Low voltage (kV)		load	no load			Real weight	Heavy with shell	
630	6 6.3 6.6 10 10.5 11	±5% ±2X2.5%	0.4	Yyn0 Dyn11	5.87	1.34	0.6	6	4	1855	1930
630					5.96	1.3	0.6		1800	1875	
800					6.95	1.52	0.5		2140	2215	
1000					8.13	1.77	0.45		2535	2620	
1250					9.69	2.09	0.45		3100	3190	
1600					11.73	2.45	0.45		3705	3830	
2000					14.45	3.05	0.4		4230	4380	
2500					17.17	3.5	0.4		5230	5380	

Installation dimension drawing

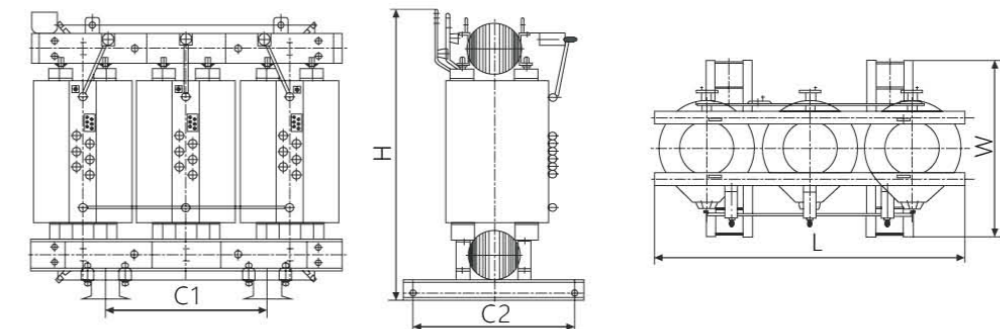

Rated Capacity (kVA)	Outline and installation dimensions (mm)				
	L	w	H	C1	C2
30	580	405	600	300	300
50	620	475	730	300	350
80	900	500	820	450	450
100	940	500	860	450	450
125	970	500	890	450	450
160	1060	650	930	550	550
200	1100	650	985	550	550
250	1140	760	1070	660	660
315	1170	760	1130	660	660
400	1360	760	1155	660	660
500	1300	760	1190	660	660
630	1370	760	1220	660	660
630	1370	760	1190	660	660
800	1440	760	1225	660	660
1000	1480	920	1330	820	820
1250	1580	920	1480	820	820
1600	1660	920	1550	820	820
2000	1720	920	1710	820	820
2500	1820	920	1780	1070	1070



Overview

The S13-MRL series three-dimensional triangular wound iron core transformer breaks through the traditional planar structure and adopts a three-phase symmetrical three-dimensional structure. And it is used in its magnetic circuit with no gaps and tighter winding. The high magnetic permeability direction of the silicon steel strip is exactly the same as the direction of the magnetic circuit. The three core columns are arranged in an equilateral triangle. , processing and cutting without waste and other characteristics, so it is a high-efficiency and energy-saving transformer that uses traditional materials, but has lower running noise and a more compact structure. Its outstanding performance in reducing losses and saving materials is fully in line with my country's energy-saving policy. It is suitable for power supply network with voltage of 35KV and below, frequency of 50Hz and 60Hz. Distribution transformer with low voltage output 400V and capacity of 10~1600KVA.

Model meaning

S 13 - MRL- □ / □
① ② ③ ④ ⑤

①	Three phase transformer
②	Performance level
③	Three-dimensional wound iron core
④	Rated capacity (kVA)
⑤	Voltage level (kV)

Technical parameter

Rated Passenger Capacity (kVA)	Voltage combination and tap range		link group label	No-load loss (kW)	Load loss (kW)	No-load current(%)	Short circuit resistance (%)
	HV(kV)	LV (kV)					
160	10 ± 5%	0.4 ± 5%	Yyn0	200	2200	1.3	4.0
200				240	2600	1.2	4.0
250				290	3050	1.2	4.0
315				340	3650	1.1	4.0
400				410	4300	1.0	4.0
500				480	5100	1.0	4.0
630				570	6200	0.9	4.5
800				700	7500	0.8	4.5
1000				830	10300	0.7	4.5
1250				970	12000	0.6	4.5
1600				1170	14500	0.6	4.5

Features

1. Energy saving, consumption reduction, noise reduction

Compared with the S7 transformer of the same capacity, the S13-MRL new energy-saving three-dimensional triangular wound iron core transformer reduces the no-load loss by 55%, the load loss by 33%, the no-load current by more than 85%, and the noise by 8db(A)-13db(A) ;

Compared with the S9 transformer of the same capacity, the no-load loss is reduced by 50%, the no-load current is reduced by more than 80%, and the noise is reduced by 8db(A)-11db(A);

Compared with the national standard S11 transformer of the same capacity, the no-load loss is reduced by more than 25%, the no-load current is reduced by 70%, and the noise is reduced by 7db(A)-10db(A);

Compared with the S13 laminated structure transformer with the same capacity, the no-load current is reduced by more than 70%, and the noise is reduced by 5db(A)-8db(A).

2. Three-phase balance

The three-dimensional triangular wound iron core is spliced by three identical single frames. The three cores are arranged in an equilateral triangle. The lengths of the magnetic paths of the three cores are exactly the same, and they are all the shortest. The losses of the three cores are the same, so Three-phase balance.

3. The quality is stable and the production efficiency is improved

The three-dimensional triangular coiled iron core is similar to the flat coiled iron core in that the iron cores are all rolled on the production line, without the need for cross-cutting equipment, which eliminates the quality fluctuation caused by manual lamination, stacking, and disassembly and insertion of iron yokes; Compared with the stacked iron core transformer, it can reduce 5-6 processes, so the production efficiency is high, the quality is stable and reliable, and it is less affected by human factors.

4. Strong short-circuit resistance

The structure of the three-dimensional triangular wound iron core transformer itself determines that its short-circuit resistance is better than that of the planar transformer for the following reasons:

(1) The cushion blocks are distributed around the body, and the center is pressed with an iron pressing plate, and the three-phase force is even and symmetrical.

(2) The compressed area of the coil is 15.7% higher than that of the plane-arranged coil. The clamp is a three-dimensional triangular frame structure, which is welded into one. Due to the stability of the three-dimensional triangle, the overall strength is large, so that the three-phase force is consistent.

5. Anti-theft

Laminated core transformers are prone to theft for technical reasons. Disassemble the solid parts of the body and knock off the silicon steel sheet of the transformer. At this time, the three windings of the transformer are immediately separated from the silicon steel sheet, and valuable materials such as silicon steel sheets and coils can be easily stolen and transported away. Since the iron core of the wound iron core transformer is a whole, the iron core cannot be knocked off and the coil cannot be taken off. It is also quite difficult to remove the integral iron core and coil, and it is not easy to separate valuable objects such as silicon steel sheets and copper wires. Therefore, the wound iron core transformer has better anti-theft performance.

6. Small footprint and beautiful appearance

The transformer oil tank adopts an approximate triangular structure, so the volume is smaller than the conventional rectangular oil tank, the structure is compact, the appearance is beautiful, and the floor area is small.

7. The product is economical and cost-effective

Compared with the laminated transformer of the same performance level, the three-dimensional triangular wound iron core transformer has lower loss value and lower cost, so it can reduce the investment cost for the user and save the operation cost for the user.

Single-phase oil-immersed transformer



Features

Western developed countries and Southeast Asia, North and South America tide regions, a large number of single-phase transformers are used as distribution transformers. In the distribution network with distributed power supply, single-phase transformers have great advantages as distribution transformers. It can reduce the length of low-voltage or electric lines, reduce line losses, and improve the quality of power supply. It adopts a high-efficiency energy-saving iron core structure design. The radius can reduce the loss of low-voltage lines by more than 60%. The transformer adopts a fully sealed structure, which has strong overload capacity, high reliability of continuous operation and simple maintenance.

It is suitable for rural power grids, remote mountainous areas, scattered villages, agricultural production, lighting and power consumption, and can also be used for railways, urban power grid energy-saving transformation of column-mounted distribution lines.

It can be operated with single phase or three single-phase or groups as three-phase operation.

Two types of single-phase distribution transformers are available

- Ordinary type and full self-protection type

—There are two kinds of iron cores, silicon steel sheet and amorphous alloy, respectively

Executive standard

ANS1 C57.12.00 C57.12.20

IEC 76

Gbl0138

Technical parameter

Rated Passenger Capacity (kVA)	Voltage combination and tap range		link group label	No-load loss (kW)	Load loss (kW)	No-load current(%)	Short circuit resistance (%)	Total weight (kg)
	HV(kV)	LV (kV)						
10	10 ± 5%	0.23	li0	0.50	0.24	2.0	3.5	210
20				0.70	0.38	1.8		270
30				0.85	0.49	1.7		300
50				0.14	0.66	1.6		350
63				0.16	0.79	1.5		400
80				0.18	0.93	1.4		460
100				0.21	1.10	1.3		520
125				0.24	1.30	1.2		580
160				0.27	1.50	1.0		650